

# SECTION 1 INTRODUCTION

## 1.1. GENERAL

This manual contains descriptive material and procedures to aid personnel in the installation, operation, maintenance and repair of the Model BASF 6106 Mini Disk Drive (Fig. 1 - 1).

## 1.2. RELATED DOCUMENTATION

Product and Interface  
Specification

80 308-038

## 1.3. DESCRIPTION

The BASF 6106 Mini Disk Drive is a very small random access storage unit, which utilizes a flexible mini disk cartridge as storage medium. The flexible disk is rotated at 300 RPM yielding a data transfer rate of 125,000 bits per second. Up to 125 kBytes of data may be stored

on a single recording surface of the mini disk when FM data recording is used. When utilizing the BASF data format of 16 sectors each with 128 bytes 81,92 kBytes of data may be recorded on the 40 tracks of the mini disk. If a data format of 9 sectors each with 256 bytes is used, 92,16 kBytes of data may be recorded. The mini disk is driven by a DC- controlled spindle drive motor, thus no AC - power is needed. The BASF 6106 uses the same tunnel erase read / write head, as is used in the BASF 6102. The head is positioned with a new four-phase DC- stepping motor actuator, utilizing a spiral wheel which gives precise location of the read/ write head on the track.

Applications for the BASF 6106 mini disk drive include word processing and text editing systems, program storage for mini and micro computers, "intelligent" desktop calculators and the micro hobby market.

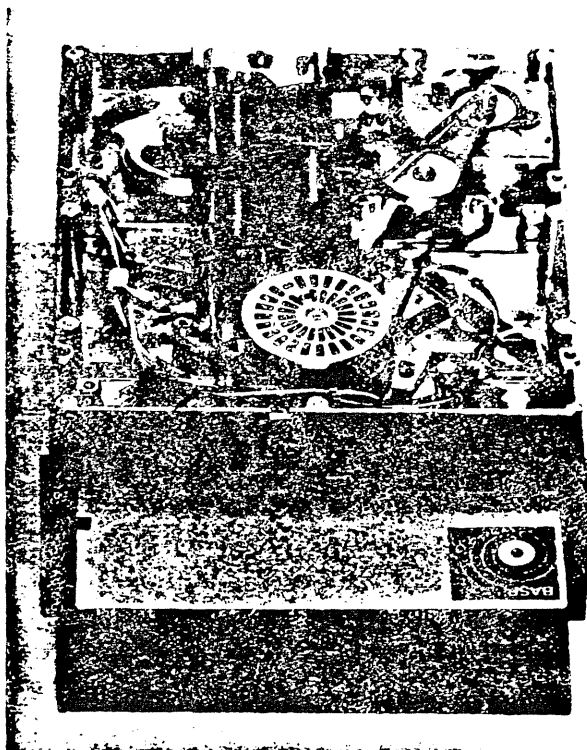

FIGURE 1 - 1 . MODEL BASF 6106 MINI DISK DRIVE

1.4. SPECIFICATION SUMMARY

A comprehensive list of principal specifications are provided in Table 1 - 1.

P E R F O R M A N C E   S P E C I F I C A T I O N S			
STORAGE CAPACITY			
Unformatted			
	per Disk (40 Tracks)	125,000	Bytes
	per Track	3,125	Bytes
Formatted			
		<u>9 SECTORS/TRACK</u>	<u>16 SECTORS/TRACK</u>
	per Disk	92,160	Bytes
	Tracks per Disk	40	Bytes
	per Track	2,304	Bytes
	Sectors per Track	9	Bytes
	per Sector	256	Bytes
TRANSFER RATE			
ACCESS TIME			
Latency			
	Maximum	200	msec
	Average	100	msec
Track to Track			
	Average	12	msec
	Average	240	msec
Head Settling Time			
	Head Load Time	max. 48	msec
	Head Load Time	max. 35	msec
	Drive Motor Start Time	max. 650	msec
F U N C T I O N A L   S P E C I F I C A T I O N S			
	Rotational Speed	300 RPM	± 2,5 %
	Recording Density (inside Track)	2768	BPI
	Flux Density	5536	FCI
	Track Density	48	TPI
	Track Radius		
	Track 00	57,15	mm (2,25 in)
	Track 39	36,5125	mm (1,4375 in)
	Encoding Method	FM	
	Media Requirements	BASF Flexidisk 5,25 or equivalent	

TABLE 1 - 1 . SPECIFICATION SUMMARY

1.5. OPTIONS SUMMARY

The following table lists the options of the 6106 mini disk drive.

1.5.1. FACTORY INSTALLED OPTION

Option	Function
Door Lock Solenoid	The door lock Solenoid locks the front door under control of the users software.

TABLE 1 - 2 . FACTORY INSTALLED OPTIONS

1.5.2. JUMPER OPTIONS

The following options are selectable by jumpers on the PCB.

Option	Function
RADIAL SELECT	Allows the connection of three mini disk drives to the host system. Each drive has its own address (0,1,2) selectable by jumper.
AUTO SELECT	The interface is always enabled (Drive is always selected). The SELECT- Lines are not used.
HEAD LOAD	<p>Loading of the head can be accomplished in three modes:</p> <ul style="list-style-type: none"> <li>• Selected Head Load (INT. SELECT • HDLOAD)</li> <li>• Auto Head Load (INT. SELECT)</li> <li>• Radial Head Load (HEAD LOAD)</li> </ul> <p>The head will be loaded only if the inserted mini disk rotates.</p>

TABLE 1 - 3 . JUMPER SELECTABLE OPTIONS

Option	Function
IN USE	Pin 34 of the interface is used as IN USE input signal and controls the door lock solenoid and the activity indicator. If this Option is used the disk change option must be disabled.
DOOR LOCK LATCH	Allows locking of the door without maintaining the IN USE signal activated by storing the state of the IN USE - signal into the IN USE - flipflop. To use this option the IN USE - option must be jumpered.
DISK CHANGE	Notifies the host system that the mini disk has been changed. If this option is used, the IN USE - option must be disabled.
DOOR LOCK	<p>Locking of the door can be accomplished as follows:</p> <ol style="list-style-type: none"> <li>1. by the IN USE - signal</li> <li>2. by the IN USE - FF (DOOR LOCK LATCH)</li> <li>3. if the drive is selected (I/O ENA activ)</li> <li>4. if the head will be loaded (HDLOADENA activ)</li> <li>5. if 1. or 3. is true</li> <li>6. if 1. or 2. or 3. is true</li> <li>7. if 1. or 4. is true</li> <li>8. if 1. or 2. or 4. is true</li> </ol>
ACTIVITY INDICATOR OPTIONS	<p>The lighting of the activity LED is selectable by jumper to one of the following conditions:</p> <ul style="list-style-type: none"> <li>• the Head is loaded and the drive is ready</li> <li>• the door is locked and the drive is ready</li> </ul>
WRITE PROTECT OPTION	Allows protection of the mini disk against over-write if the write protect notch is open (ECMA) or if the write protect notch is closed (SHUGART).
STEPPER MOTOR SWITCHING	The stepper motor is switched on and off together with the drive motor if a jumper is inserted. If the jumper is not inserted the stepper motor will be enabled as long as power is supplied.

**PHYSICAL SPECIFICATIONS**

**Environmental limits**

ambient temperature (operation)	10° to 50°C (50° F to 120° F)
Relative humidity	20 % to 80 %
Maximum wet bulb	29°C (84°F)
DC- voltage requirements	+ 12 VDC ± 5% max. 1,75 A * max.100 mV pp ripple
	+ 5 VDC ± 5% max. 0,7 A max.50 mV pp ripple
	* plus motor starting current max. 1,4 A for max. 100 msec
<b>Power Dissipation:</b>	10 watts operating 4,0 watts stand by (motor off) 7,5 watts motor- on and deselected

**Mechanical Dimensions**

Width	146,1 mm (5,75 in.)
Height	53,5 mm (2,11 in.)
Depth	196,5 mm (7,74 in.)
Weight	1,4 kg

**RELIABILITY SPECIFICATIONS**

<b>MTBF:</b>	8000 POH under typical usage *
<b>Unit Life Time:</b>	five years
<b>MTRR:</b>	30 minutes
<b>Error Rates:</b>	
Soft Read Errors:	1 per 10 <sup>8</sup> bits read
Hard Read Errors:	1 per 10 <sup>11</sup> bits read
Seek Errors :	1 per 10 <sup>6</sup> seeks
<b>Media Life:</b>	
Passes per Track:	5 x 10 <sup>6</sup>
Insertions :	30 000
	* Duty cycle of Spindle Drive Motor: 25 % of POH

**MEDIA SPECIFICATIONS**

<b>Jacket:</b>	133,4 mm (5,25 in.) square
<b>Disk :</b>	130,2 mm (5,125 in.) diameters
<b>Center Hole:</b>	28,575 mm (1,125 in.)

TABLE 1 - 1 (continued). SPECIFICATION SUMMARY

1.6. RECORDING MEDIA

The BASF Mini Disk Drive uses a removable single sided flexible mini disk as storage media. Fig. 1 - 2 shows construction and dimensions of a typical mini disk. The recommended recording media for use with the BASF 6106 is the BASF mini disk 606. The mini disk is an oxide coated flexible disk enclosed in a protective plastic envelope. The protective envelope contains aperture for head contact, index detection, write protect detection and spindle loading.

The write protect notch is used to protect the written data on the mini disk (see 2. 2. 6. Write Protect Detector).

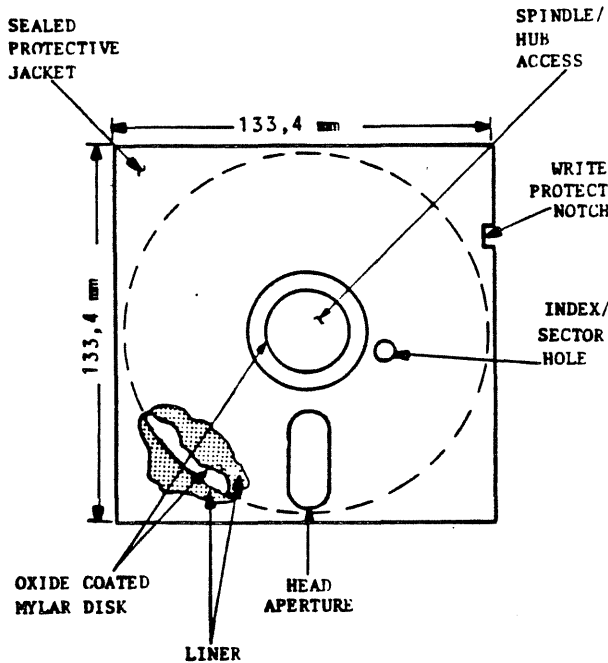

FIGURE 1 - 2 . FLEXIBLE DISK CONSTRUCTION AND DIMENSIONS

1.7. RECORDING FORMAT

The format of the data recorded on the mini disk depends on the host system. The normally used encoding scheme for the BASF 6106 mini disk drive is frequency modulation recording (FM). This scheme utilizes clocks to define bit cell times. The presence of a flux reversal between clock pulses is defined as a "one" bit. The absence of a flux reversal between clocks is defined as a "zero" bit. On the write data and read data interface lines between mini disk drive and host system every pulse represents a flux reversal on the mini disk.

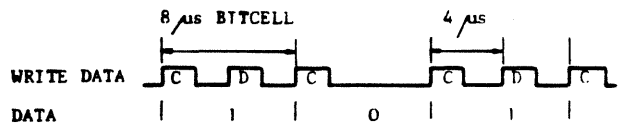

FIGURE 1 - 3 . FM - ENCODING

A group of eight consecutive bit cells orbit positions (B8 - B1) defines a byte. The most significant bit is defined as B8, the least significant bit is B1, as shown on fig. 1 - 4. During a write operation, the most significant bit B8 is always transferred first. Also, when the data is being read back from the drive, bit 8 of each byte will be transferred first.

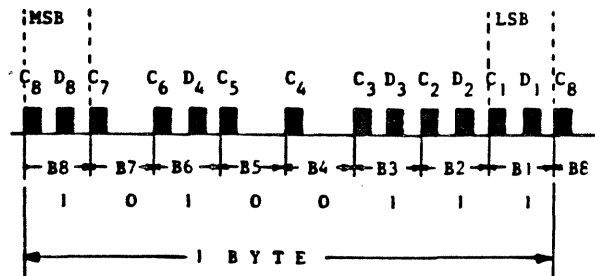

FIGURE 1 - 4 . BYTE

## 1.8. TRACK FORMAT

The tracks of the mini disk may be formatted in numerous ways, depending on the formatter of the using system. The BASF 6106 can write and read hard or soft sectored track formats.

### 1.8.1. SOFT SECTORED TRACK FORMATS

In a soft sectored track format the user may record one long record or several smaller records on a track. Two soft sectored track formats with 16 and 9 sectors per track are described in the following chapters.

#### 1.8.1.1. SOFT SECTORED TRACK FORMAT WITH 16 SECTORS/TRACK a' 128 BYTES

This format, which is recommended from BASF, is shown fig. 1 - 6. It is similar to the IBM - format.

The beginning of a track is indicated by a physical index pulse. Every record is preceded by a unique record identifier. Record identifiers and data fields are separated by gaps. The gaps are necessary to allow the updating of a data field without disturbing adjacent fields.

#### INDEX GAP

This gap starts with the index pulse and is always 16 bytes in length. It is not affected by any update write.

#### IDENTIFIER GAP

This gap consists of 11 bytes  $FF_x$  and may vary slightly in length after the data field has been updated.

#### DATA GAP

This gap separates the data field from the following ID- field and is 27 bytes in length. It will vary slightly in length after the data field has been updated.

## TRACK GAP

The gap between the last data field and the index puls is defined as Track Gap. It varies slightly in length, due the write frequency tolerances and the disk speed tolerances. It is nominally 101 bytes in length.

### ADDRESS MARK (AM)- BYTE

The soft sectored track format needs unique bit patterns to identify the beginning of ID and Data Fields for synchronizing the deserializier circuit in the host system. The unique bit pattern is called Address Mark (AM). AM- patterns do not contain clock bits in all bit cells (all other data bytes must have clock bits in every bit cell!).

There are three different AM- patterns used:

- ID- AM in front of a ID-Field
- DATA - AM in front of a Data Field
- DELETED DATA- AM in front of a Deleted Data Field

These AM are shown on Fig. 1 - 5.

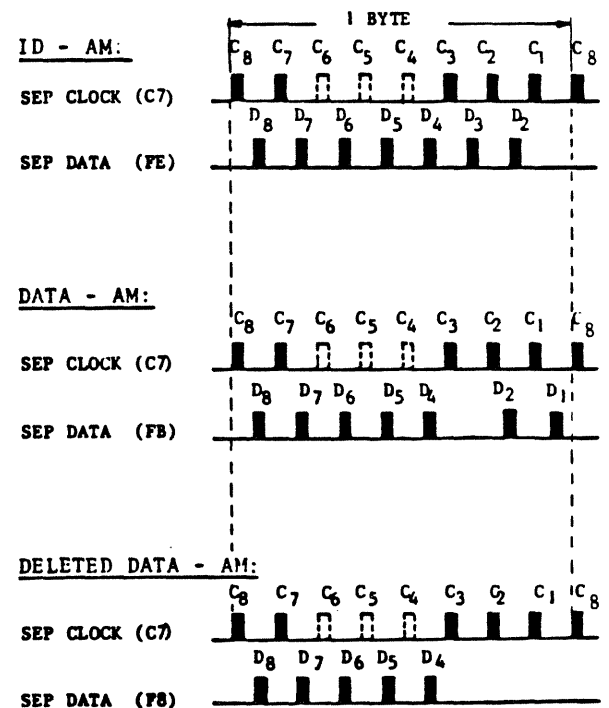

FIGURE 1 - 5 . ADDRESS MARK PATTERN

**SECTOR IDENTIFIER**

The sector identifier consists of the identifier mark, the address identifier and the EDC pattern.

**IDENTIFIER MARK**

This field comprise 7 bytes (see Fig.1-6). The 6 bytes of zeros in front of the address mark byte are for synchronisation of the data separator in the host system. The ID-AM byte contains a data pattern of FE where the clock bits C6, C5 and C4 are missing as explained before.

**ADDRESS IDENTIFIER**

The address identifier comprises the following 6 bytes.

**TRACK ADDRESS**

This byte represents in binary notation the track address from 00 for the outermost track to 39 for the innermost track.

**2ND BYTE OF THE ADDRESS IDENTIFIER**

This byte contains always 00.

**SECTOR ADDRESS**

Represents in binary notation the sector address from 01 for the 1st sector to 16 for the last sector of a track.

**4TH BYTE OF THE ADDRESS IDENTIFIER**

This byte shall be always a (00-) byte.

**EDC - BYTES**

These two bytes are hardware generated from the host system by shifting serially the bits of the sector identifier starting with the ID-AM and ending with the 4th byte of the sector identifier through a 16-bit shift register described by the generator polynomial:

$$x^{16} + x^{12} + x^5 + 1.$$

(For more details read chapter EDC- implementation!)

INDEX GAP	SECTOR IDENTIFIER	IDENTIFIER GAP	FIRST DATA BLOCK	DATA BLOCK GAP	LAST DATA BLOCK	DATA BLOCK GAP	TRACK GAP
16 X FF	13 BYTES	11 X FF	137 BYTES	27 X FF	137 BYTES	27 X FF	101 X FF



**SECTOR IDENTIFIER:**

IDENTIFIER MARK	ADDRESS IDENTIFIER	EDC
6 X 00 FE 1) C7 2)	TRK 00 SEC 00	2 BYTES

ID-AM

**DATA BLOCK:**

DATA	MARK	DATA FIELD	EDC
6 X 00	FE 1) C7 2)	128 BYTES	2 BYTES

DATA-AM

- 1) DATA PATTERN
- 2) CLOCK PATTERN
- DELETED AM : FB

**ID - AM:**

SEP CLOCK (C7)

SEP DATA (FE)

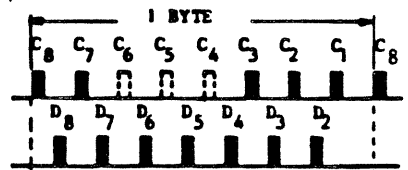

**DATA - AM:**

SEP CLOCK (C7)

SEP DATA (FB)

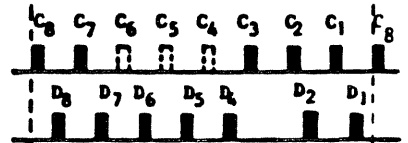

**DELETED DATA - AM:**

SEP CLOCK (C7)

SEP DATA (FB)

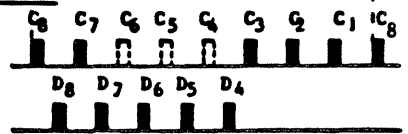

FIGURE 1 - 6 . SOFT SECTORED TRACK FORMAT WITH 16 SECTORS/TRACK

## DATA BLOCK

The data block contains the data mark, the data field and the EDC- bytes.

## DATA MARK

This field comprises 7 bytes (see Fig. 1-6). The 6 bytes of zeros in front of the data address mark are for synchronisation of the data separator circuit in the host system. The data address mark byte contains FB in front of a normal data field. When a deleted data field follows, F8 must be written. The clock pattern of the data address mark is C7 (C6, C5 and C4 missing).

## DATA FIELD

This field comprises 128 bytes. If it comprises less than 128 bytes, the remaining positions shall be filled with zeroes.

## EDC - BYTES

These two bytes are hardware generated by the host system by shifting serially the bits of

the data block starting with the Data- AM and ending with the last byte of the data field through a 16- bit shift register described by the following generator polinomial:

$$x^{16} + x^{12} + x^5 + 1$$

## EDC- IMPLEMENTATION

Fig. 1-7 is a simplified logic of a shift register, which may be used to generate the EDC bytes.

Prior to the operation, all positions of the shift register are set to ONE. Input data are added (exclusive OR) to the contents of position C<sub>15</sub> of the register to form a feedback. This feedback is in its turn added (exclusive OR) to the contents of position C<sub>4</sub> and position C<sub>11</sub>.

On shifting, the outputs of the exclusive OR gates are entered respectively into positions C<sub>0</sub>, C<sub>5</sub> and C<sub>12</sub>. After the last data bit has been added, the register is shifted once more as specified above.

The register then contains the EDC bytes. If further shifting is to take place during the writing of the EDC bytes, the control signal inhibits exclusive OR operations.

To check for errors when reading, the data bits are added into the shift register in exactly the same manner as they were during writing. After the data the EDC bytes are also entered into the shift register as if they were data. After the final shift, the register contents will be all ZERO if the record does not contain errors.

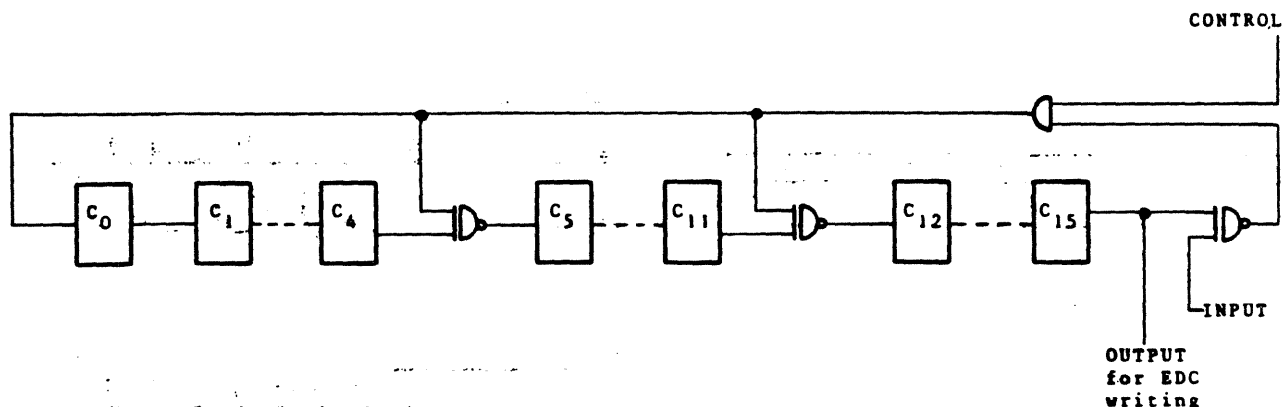

FIGURE 1 - 7 . SIMPLIFIED EDC SHIFT REGISTER



1.8.1.2. SOFT SECTORED TRACK FORMAT WITH 9 SECTORS PER TRACK

In this format, which is shown on Fig. 1 - 8, each sector contains 256 bytes.

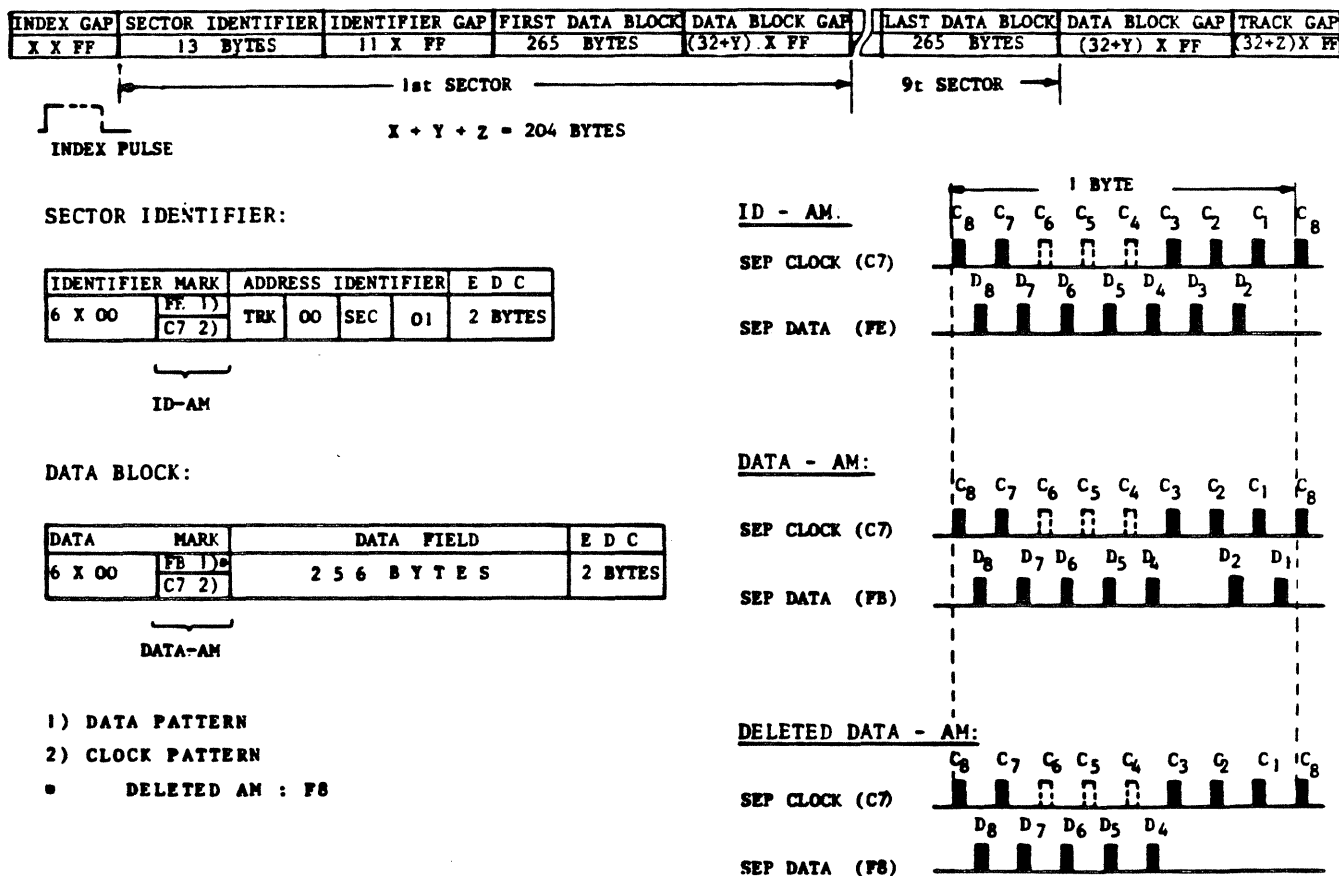
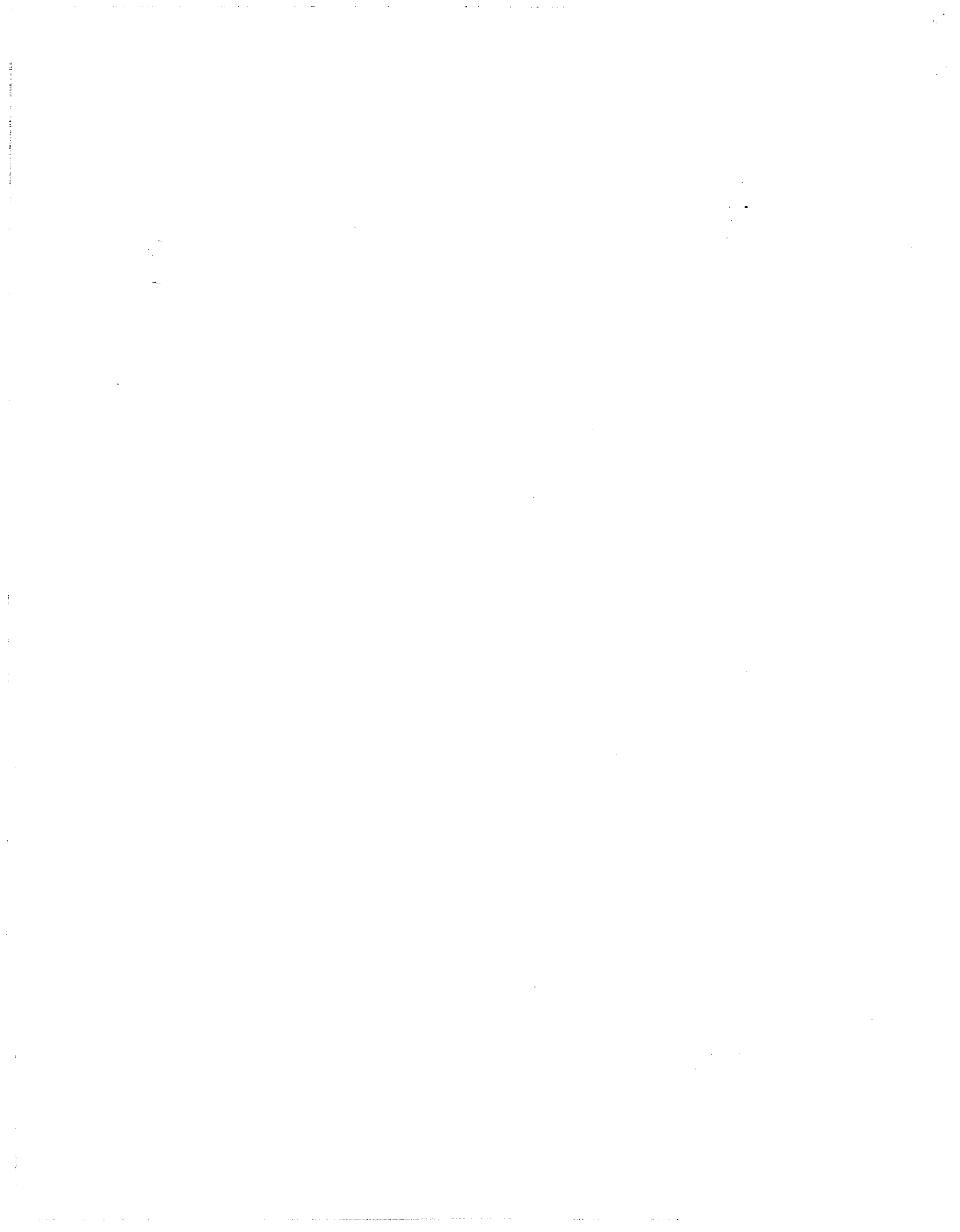

FIGURE 1 - 8 . SOFT SECTORED TRACK FORMAT WITH 9 SECTORS/TRACK



# SECTION 2

## THEORY OF OPERATION

### 2.1. FUNCTIONAL DESCRIPTION

The BASF 6106 comprises the following mechanism functional circuits (see Fig. 2 - 1).

Mechanism:

- Drive Mechanism
- Spindle and Front Door Mechanism
- Positioning Mechanism
- Head Load Mechanism

Functional Circuits:

- Interface
- Drive Motor Control
- HEAD LOAD-, DOOR LOCK- and ACTIVITY LED- Driver
- Track Zero Detector
- Write Protect Detector
- Index / Ready Detector
- Read / Write Circuits
- DC- Control and Power On Reset Logic

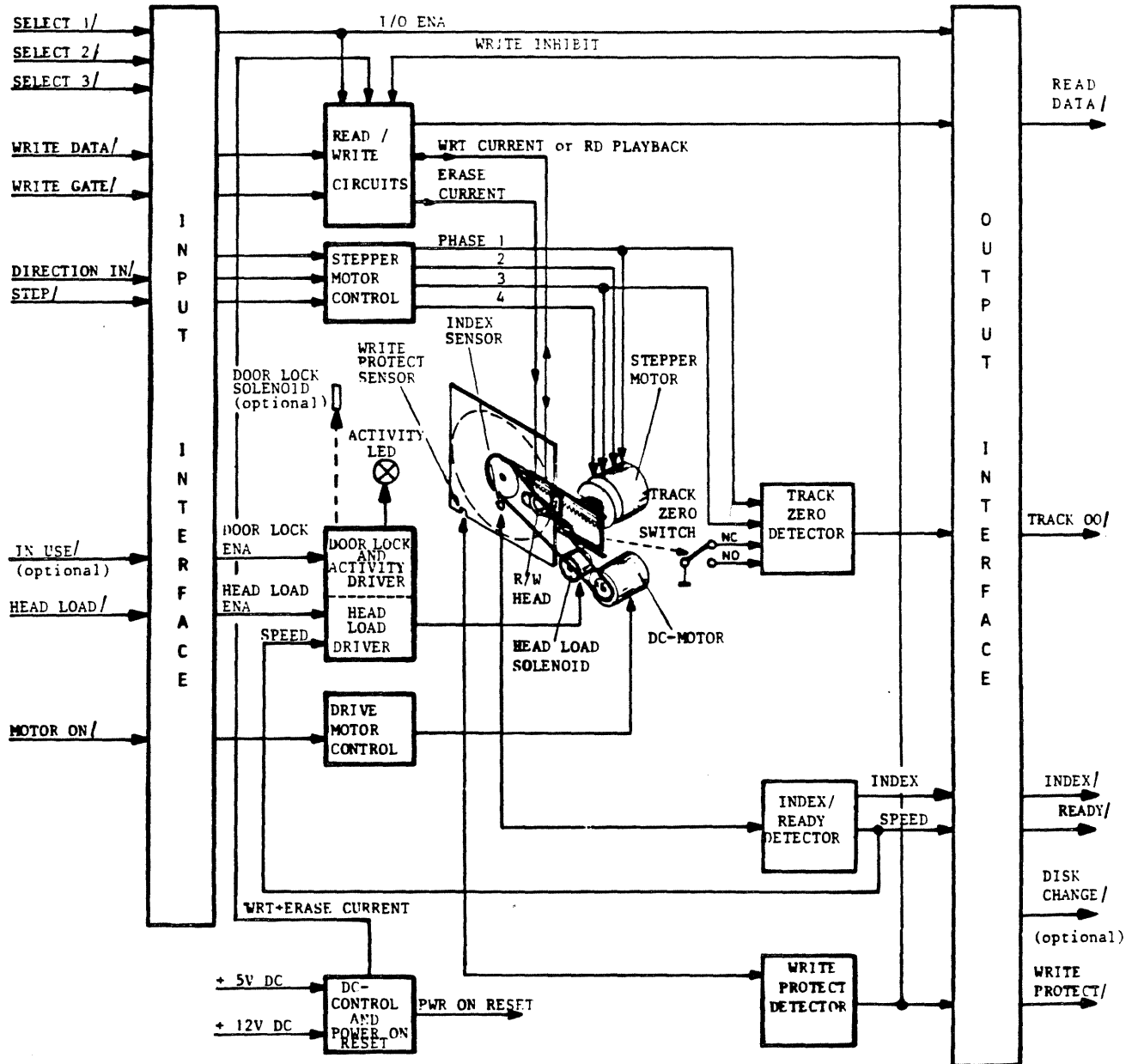

FIGURE 2 - 1 . BLOCK DIAGRAM BASF 6106

### 2.1.1. DRIVE MECHANISM

The spindle is rotated at 300 rpm by a DC drive motor. Rotation of the spindle is provided by a belt and pulley. The drive motor is started and stopped by the interface signal MOTOR ON.

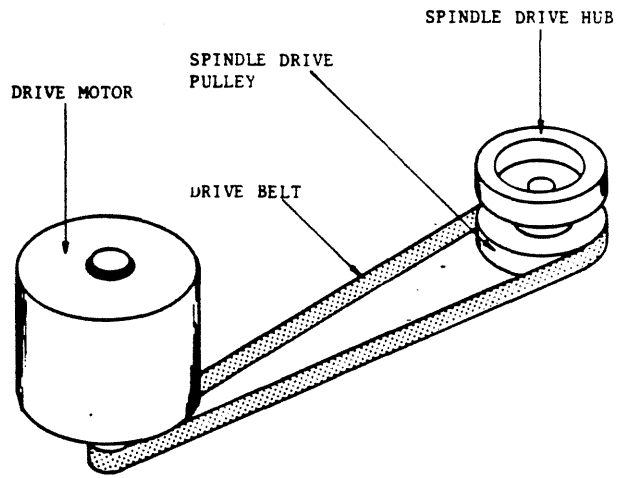

FIGURE 2 - 2 . DRIVE MECHANISM

### 2.1.2. SPINDLE AND FRONT DOOR MECHANISM

The main parts of this mechanism are the drive hub, the centering cone, the centering cone expander and the front door with pressure arm and door latch. (see Fig.2 - 3 ) For loading a disk the mini disk is inserted and the front door pressed. The pressure arm moves down , the centering cone enters the mini disk. Just before the centering cone reaches the fully down position, the centering cone expander is

activated and expands the centering cone which grips the inner diameter of the mini disk to ensure correct alignment. The door latch is activated and holds the front door in a closed position. For unloading a disk, the front door must be pressed again. The door latch opens and the pressure arm is moved upwards by a spring. The centering cone and centering cone expander also move upwards and disengages the mini disk from the drive hub.

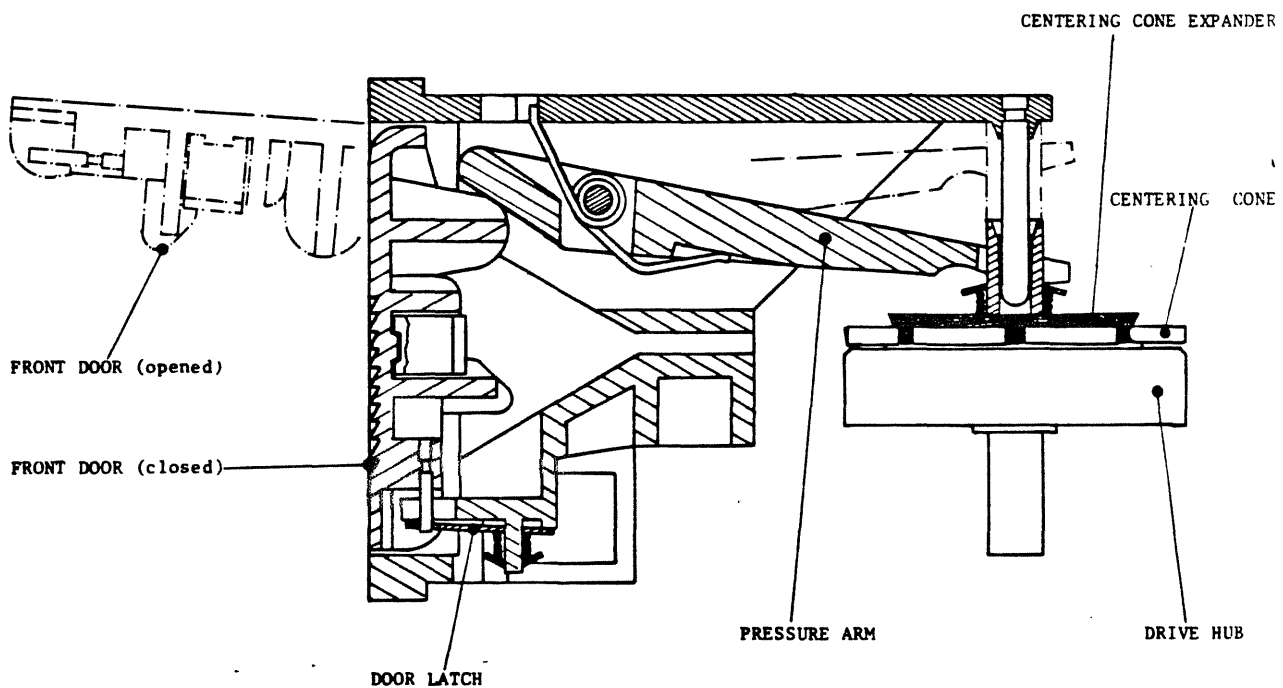

FIGURE 2 - 3 . SPINDLE AND FRONT DOOR MECHANISM

### 2.1.3. POSITIONING MECHANISM

The main parts of the positioning mechanism are (see Fig. 2 - 4 ).

- Stepper Motor
- Spiral Wheel
- Carriage Assembly

The stepper motor is a four phase motor and is rotated  $15^{\circ}$  by every step pulse. The spiral wheel directly connected to the shaft of the

stepper motor converts the rotational motion of the stepper motor to a linear motion of the read write head.

The carriage assembly consists of the read/write head, the head load pressure arm and two guide bars. The read/write head is inserted in the carriage assembly, which rides on the two guide bars. The mini disk is pressed against the read/write - head load pressure arm. The head load pressure arm is released by the head load mechanism.

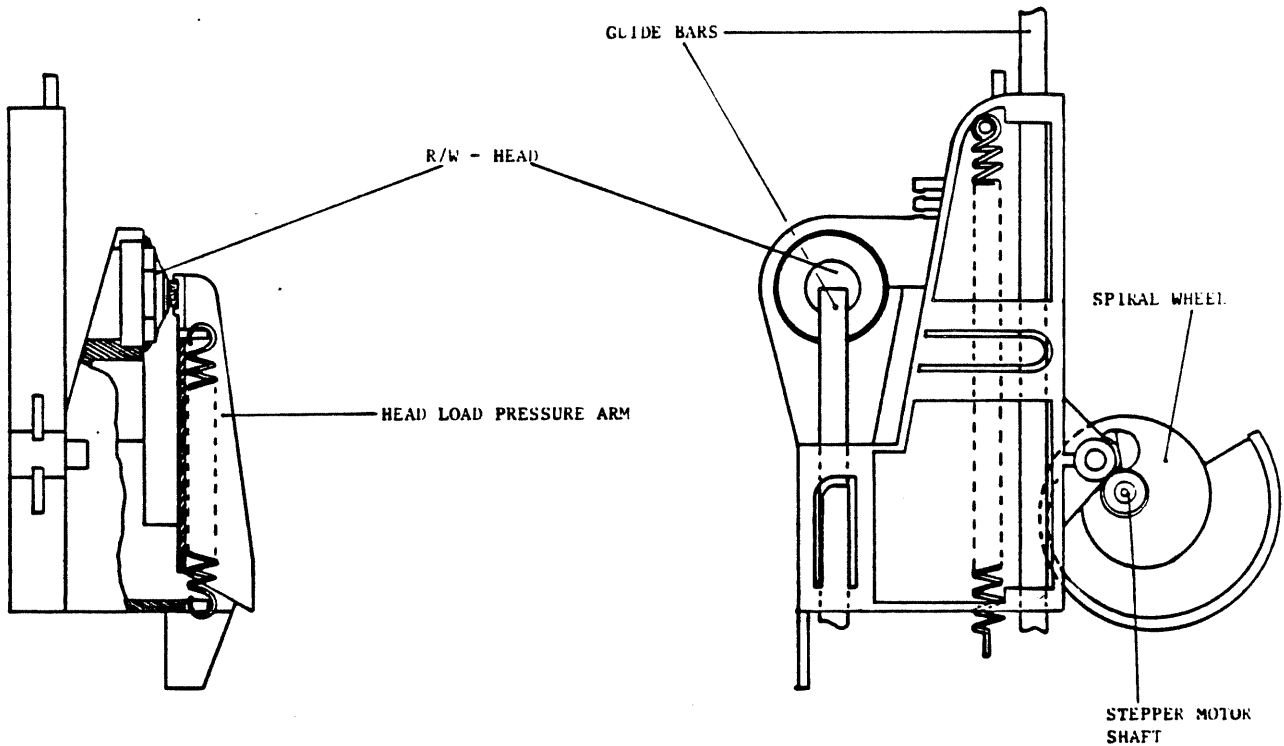

FIGURE 2 - 4 . POSITIONING MECHANISM

#### 2.1.4. HEAD LOAD MECHANISM

The head load mechanism comprises (see Fig. 2 - 5 ).

- Head Load Solenoid
- Head Load Actuator

When the head load solenoid is energized the head load actuator releases the head load pressure arm of the carriage assembly, which in turn presses the mini disk against the read/write head by the head load pad. The pressure pad under the head load actuator stabilizes the mini disk. When the head load solenoid is de-energized, the head load actuator is lifted by a spring. Also the head load pressure arm is lifted.

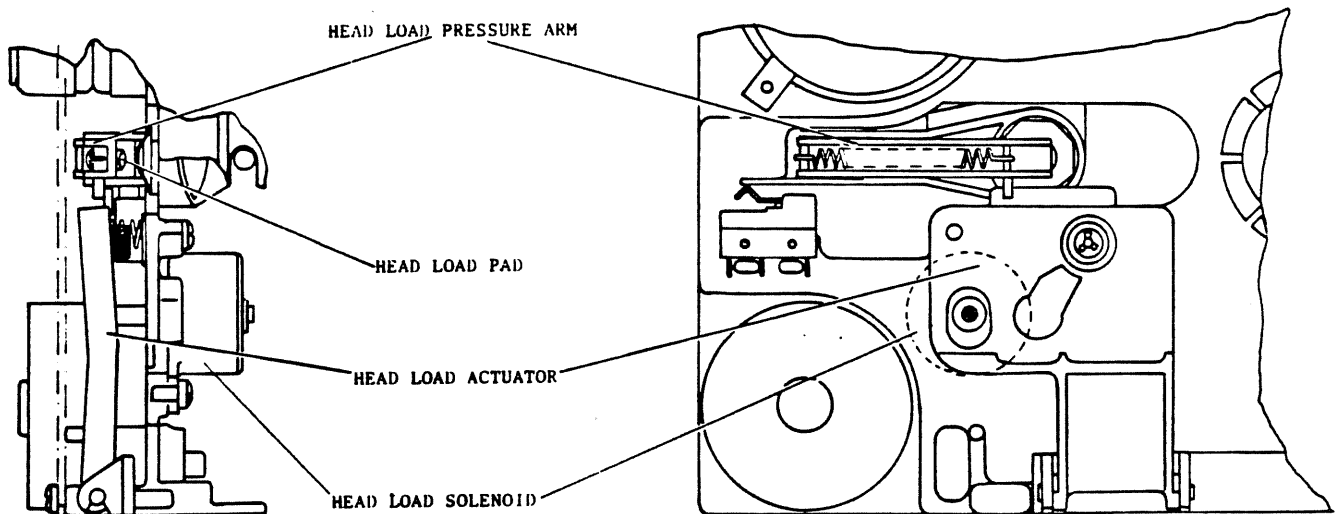

FIGURE 2 - 5 . HEAD LOAD MECHANISM

## 2.2. LOGIC DESCRIPTION

### 2.2.1. INTERFACE LOGIC

The interface logic consists of two parts.  
(see Fig.2 - 6 )

- the input interface
- the output interface

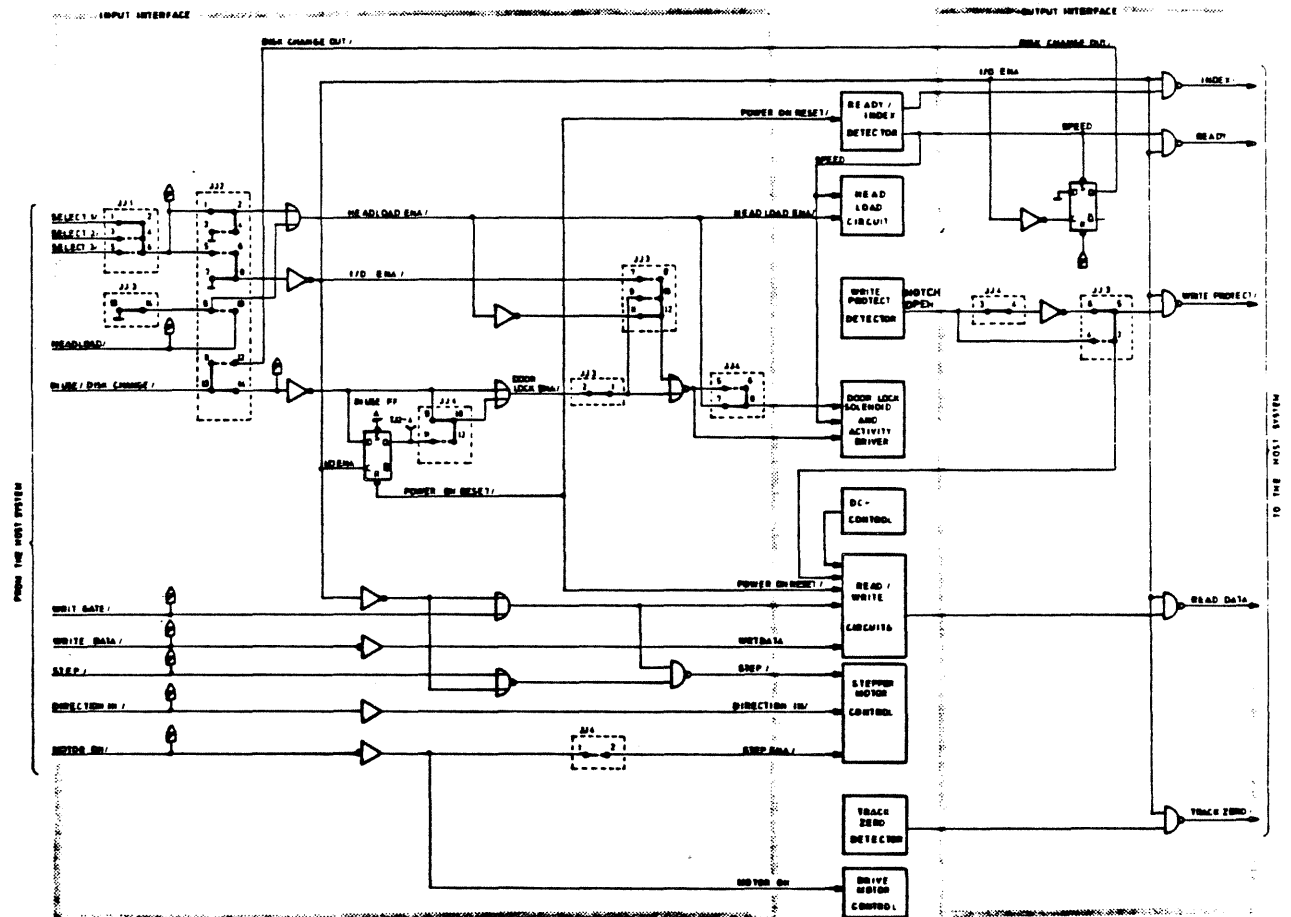

FIGURE 2 - 6 . INTERFACE LOGIC

### 2.2.1.1.INPUT INTERFACE

The input interface receives the signals from the host system Table 2 - 1 lists and defines the input signals.

The input lines are terminated by pull up resistors of 150 Ohm. In a radial configuration only the last drive will contains the pull up resistor network.

The receivers sends the input lines to the different parts of the drive electronics.

SIGNAL NAME	DEFINITION
SELECT (1-3) /	Selects the desired mini disk drive. Enables when used all other interface lines except MOTOR ON and DIRECTION IN.
WRITE DATA /	This line carries low active pulses representing data to be recorded on the mini disk 
WRITE GATE /	Low input enables recording of WRITE DATA on disk High input enables reading from the mini disk
MOTOR ON /	This line turns on the drive motor and the stepper motor and is not gated by SELECT. A recalibrate operation must be performed to obtain correct head positioning every time after the MOTOR ON signal goes active. Switching of the stepper motor may be disabled by removing a jumper. This avoids recalibrating after switching on the drive motor.
DIRECTION IN /	Defines motion of the read write head LOW = in (towards Track 39) HIGH = out (towards Track 0) This line is not gated by select
STEP /	Used in conjunction with DIRECTION IN and causes the read/write head to be moved from track - to - track.
HEAD LOAD /	This line is used to press the mini disk against the read/write head if the mini disk drive is ready. To activated this line a jumper has to be changed.
IN USE / (OPTION)	This line controls the door lock solenoid. Also the activity LED can switched on. If the IN USE / signal is used, the disk change option must be disabled.

TABLE 2 - 1 . INPUT SIGNALS

### 2.2.1.2.OUTPUT INTERFACE

The output interface sends the read data pulses and the status signals WRITE PROTECT, INDEX, READY, TRACK 00 and DISK CHANGE (optional) to the host system (see Table 2 - 2). The output signals are gated by I/O- ENABLE and driven by the output drivers SN 7438.

SIGNAL NAME	DEFINITION
READ DATA /	This Line provides the " raw data " as detected by the read electronics. 
WRITE PROTECT /	Low active status indicates that a write protected mini disk is installed. The BASF 6106 will inhibit writing with a write protected mini disk installed.
INDEX /	The leading edge of this signal indicates the beginning of a track when soft sector format is used. 
TRACK 00 /	This Line indicates that the read / write head is positioned at track 00.
READY /	This line indicates that the inserted mini disk has reached more than 60 % of full operation speed and two consecutive INDEX- pulses has been sensed. For hard sectored mini disks Ready is activated as soon as the mini disk starts turning and two consecutive SECTOR pulses has been sensed.
DISK CHANGE / (OPTION)	A active (low) signal is provided when the SELECT- line is activated if the drive while deselected has gone from a Ready to a Not Ready condition.

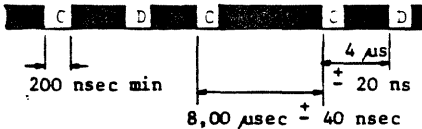
TABLE 2 - 2 . OUTPUT SIGNALS



### 2.2.1.3. JUMPER OPTIONS

The following options can be selected by jumpers:

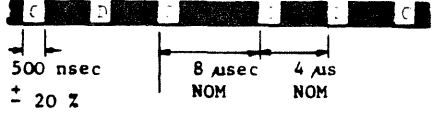
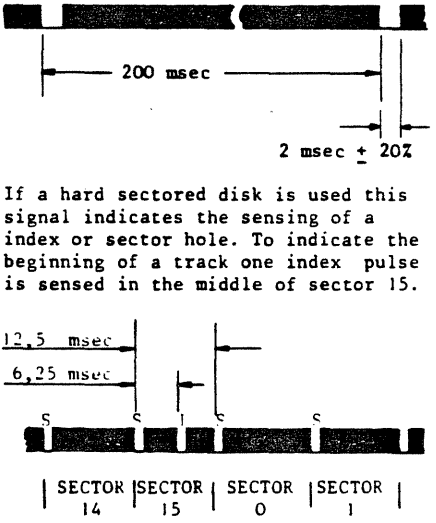
- Select Options
- Head Load Options
- IN USE Options
- Door Lock Latch Option
- Door Lock Options
- Activity LED Option
- Write Protect Option
- Stepper Motor Switching

#### Select Options

There are two possibilities to select the mini disk drive.

- Auto Select
- Radial Select

#### Auto Select

This option is used when no SELECT-lines are used. The input and output interface are always enabled, because I/O- ENA is forced to a high. To install the AUTO SELECT option PIN 7 and 8 of JJ2 must be jumpered (see Fig. 2 - 7).

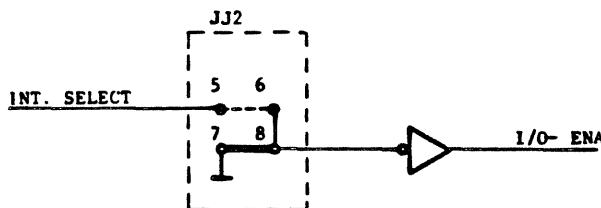

FIGURE 2 - 7 . AUTO SELECT OPTION

#### Radial Select

If Radial Select is used max. three mini disk drives can be connected to the host system. The signal SELECT 1/ will select the mini disk drive jumpered between JJ1 1-2, SELECT 2/ will select the mini disk drive jumpered between JJ1 3-4 and SELECT 3/ will select the mini disk drive jumpered between JJ1 5-6. Only one select jumper is allowed in one drive. For enabling of the Radial Select Option JJ2 5-6 must be jumpered and the Auto Select Option must be disabled by removing Jumper JJ2 7-8.

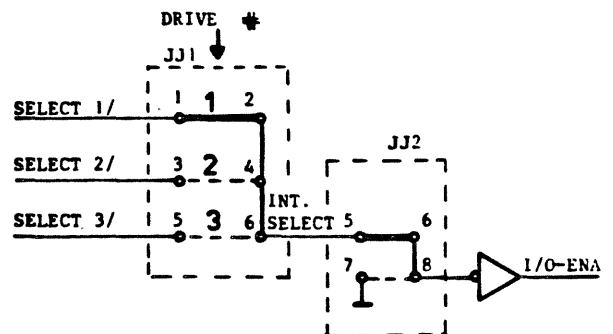

FIGURE 2 - 8 . RADIAL SELECT OPTION

## Head Load Options

There are three possibilities for the user to load the head.

- Auto Head Load
- Selected Head Load
- Radial Head Load

### Auto Head Load

This Option allows the user the read / write head to be load as soon as the mini disk drive is selected. If auto head load is desired the jumpers must be set as shown in Fig. 2-9 .

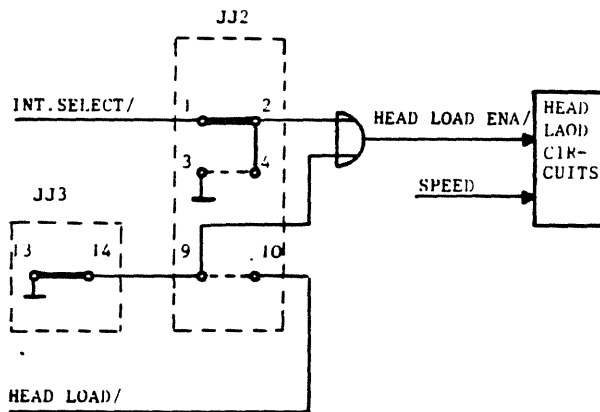

FIGURE 2 - 9 . AUTO HEAD LOAD OPTION

### Selected Head Load Option

In this configuration the head is loaded when the mini disk drive is selected and the HEAD LOAD signal is activated (see Fig.2-10).

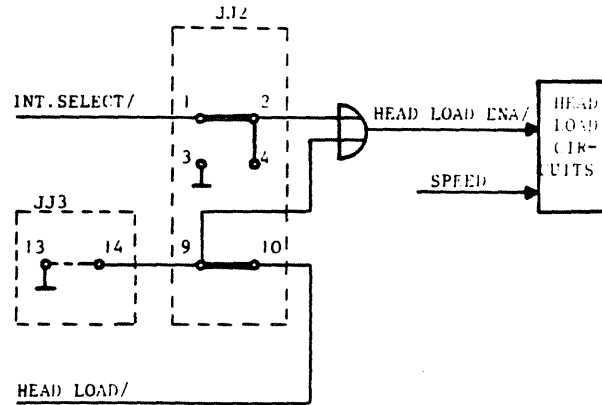

FIGURE 2 - 10 . SELECTED HEAD LOAD OPTION

### Radial Head Load Option

This option allows the user to keep the head loaded without selection of the mini disk drive. The 48 msec head load time is then eliminated. To install this option see Fig. 2 - 11 .

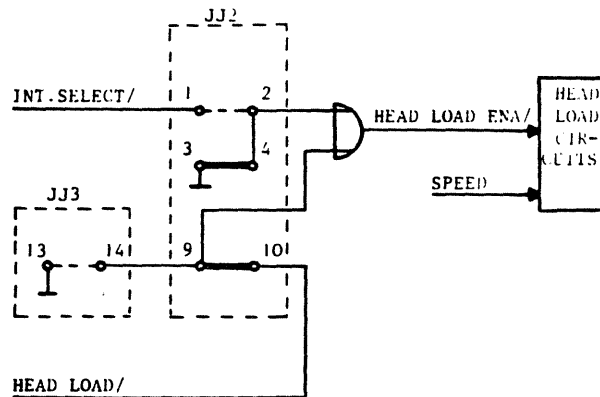

FIGURE 2 - 11 . RADIAL HEAD LOAD OPTION

**Door Lock Latch Option (Fig. 2 - 12)**

This option can be used if the IN USE Option is already installed. Then, the door lock latch option will allow the latching of the door lock solenoid under control of the SELECT and IN USE signals without maintaining the IN USE signal activated. The IN USE-FF stores the state of the IN USE- signal when the drive is selected (see Fig. 2 - 13). The door lock solenoid remain activated even if the mini disk drive is deselected and the IN USE- signal is deactivated. To unlock the door the mini disk drive must be selected again with IN USE inactive (low). To enable the Door Lock Latch Option a jumper must be installed on JJ2 between Pin 11 and 12.

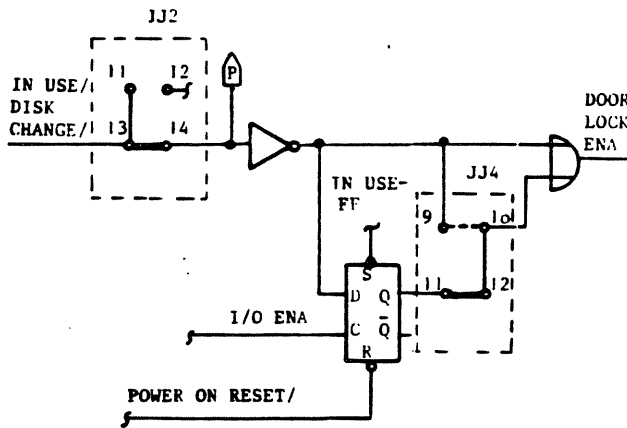

FIGURE 2 - 12 . DOOR LOCK LATCH OPTION

**IN USE Option**

Pin 34 of the interface can be used for the In Use option if JJ2 is jumpered from Pin 13 to 14. The IN USE- Signal is used to turn on the door lock solenoid, also the IN USE signal can be used to turn on the activity LED.

If the IN USE option is used the DISK CHANGE Option must be disabled by removing the jumper on JJ2 between PIN 11 and 12.

**Write Protect Option**

This option allows the user to decide by setting of jumpers in which fashion the mini disk is protected against overwriting. He can selecting that the mini disk is protected either if the Notch are open or if the notch is covered as shown on the following table.

JUMPER	NOTCH OPEN	NOTCH COVERED	REMARKS
JJ4:3-4 JJ3:5-6	unprotected	protected	Shugart
JJ3:3-4	protected	unprotected	ECMA-Norm

TABLE 2 - 3 . WRITE PROTECT JUMPERING

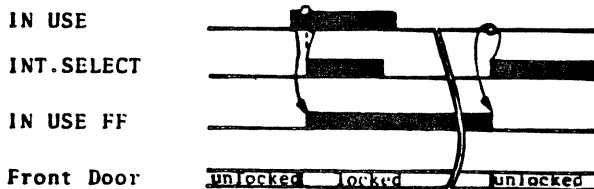

FIGURE 2 - 13 . TIMING DIAGRAM DOOR LOCK LATCH OPTION

**Stepper Motor Switching**

The stepper motor can be switched on and off by the MOTOR ON- signal, if there is a jumper installed between JJ4 Pin 3 and 4. If this jumper is installed the mini disk drive must be repositioned by a recalibrate operation every time the drive and stepper motor are turned on.

### Door Lock Options

There are several possibilities to lock the front door:

1. Locking by the IN USE signal
2. Locking by the Door Lock Latch Option
3. Locking while the drive is selected
4. Locking while the head is loaded

Also the circuit allow combinations of the possibilities written above:

5. If 1. or 3. is true
6. If 1. or 2. or 3. is true
7. If 1. or 4. is true
8. If 1. or 2. or 4. is true

### Locking by the IN USE signal

The front door is locked as long as the IN USE- signal is activated. For this option the following jumpers must be installed.

JJ2	JJ3	JJ4
13-14	1 - 2 9 - 10	9-10

### Locking by the Door Latch Option

The front door stays locked as long as the IN USE- FF is set. The following jumpers must be installed:

JJ2	JJ3	JJ4
13- 14	1 - 2 9 - 10	11-12

### Locking while the drive is selected

The front door is locked as long as the drive is selected. The jumpers must be set as follows:

Install:	JJ2	JJ3	Remove:	JJ3
	5 - 6	7 - 8 9 - 10		1 - 2

### Locking while the head is loaded

The front door is locked as long as the read/write head is loaded. To allow this option the following jumpers must be installed.

Install:	JJ3	Remove:	JJ3
	11-12 9-10		1 - 2

Combinations of the previous described possibilities

If combinations of the above described door lock options are wished to use for locking the front door, the jumper JJ3 9-10 must be removed. The following combinations are possible.

DOOR LOCK = DOOR LOCK ENA + HEAD LOAD ENA  
 DOOR LOCK = DOOR LOCK ENA + I / O ENA  
 DOOR LOCK = DOOR LOCK ENA + IN USE + IN USE FF

To install this combinations all jumpers of the wished combination must be installed except JJ3 9 - 10. (see also Installation and Operation)

### Activity Indicator Options

The activity indicator is switched on when the drive is up to speed (SPEED-FF is set) and the read/write head is loaded (Jumper JJ4: 7 - 8) or the door is locked (Jumper JJ4:5-6).

Disk Change Option (Fig. 2-14 )

PIN 34 of the interface can be used for the Disk Change Option when the In Use Option is not used. The DISK CHANGE - Signal notifies the host system that the mini disk has been changed even if the drive was deselected. As soon as the mini disk is unloaded the speed detector will deactivate the SPEED-signal and the DISK CHANGE - FF is set. The DISK CHANGE signal is sent to the host system when the

drive is selected. The DISK CHANGE -FF will stay set when the new mini disk is loaded. To deactivate the DISK CHANGE- signal the host system must deselect the drive again. The DISK CHANGE- FF is then reset (see timing diagram Fig. 2-15 ). To enable the Disk Change Option a Jumper be installed at JJ 2 Pin 11 and 12.

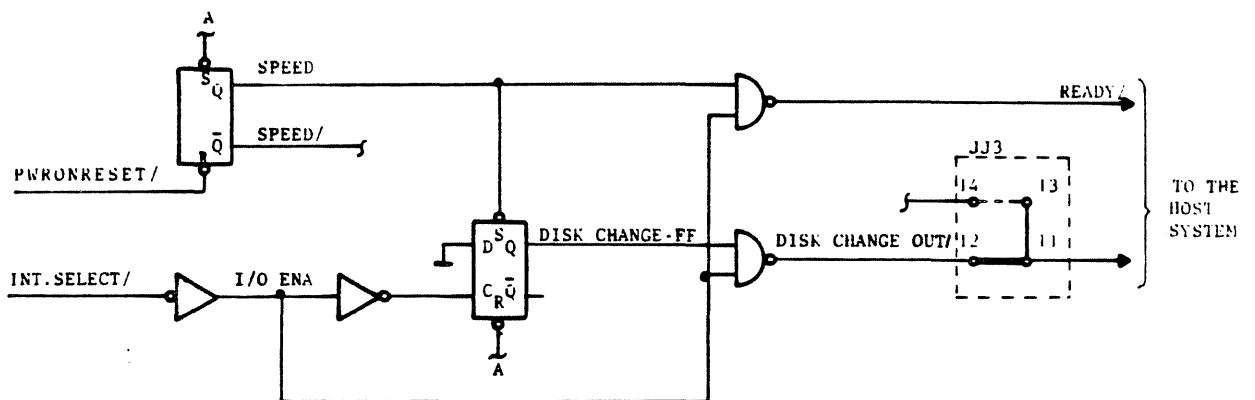

FIGURE 2 - 14 . DISK CHANGE LOGIC

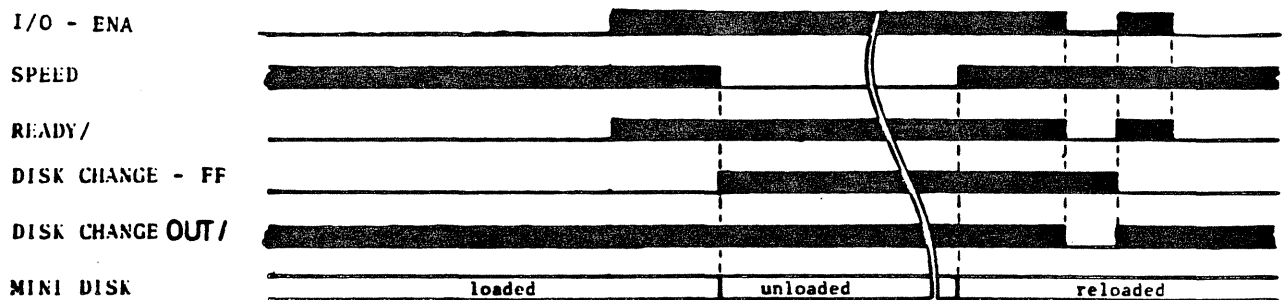

FIGURE 2 - 15 . TIMING DIAGRAM DISK CHANGE LOGIC

### 2.2.2. STEPPER MOTOR CONTROL

The stepper motor is a four phase DC - motor and is controlled by the integrated circuit SAA 1027. This IC comprises the stepper motor drivers, a synchron counter and control circuits (see Fig. 2 - 16). Each STEP pulse from the host system rotates the stepper motor for one step. Each step corresponds to a rotating angle of 15°. The rotation of the stepper motor is converted to a linear motion of the R/W- head by the spiral wheel. The direction of the motion of the R/W- head depends on the input signal DIRECTION IN/. If this signal is active (low) the R/W-head will be moved towards track 39 (in). The R/W-head moves out by each STEP-pulse, when DIRECTION IN /

is in a high state. Multiple track positioning is attained by the host system issuing a series of STEP pulses at 12 msec intervals. Table 2-4 shows the output signals for "in" and "out" motion of the R/W- head. The DIRECTION IN signal must be at the desired level 1 µsec before the trailing edge of the STEP pulse. Stepping is initiated by the trailing edge of the step pulse. The time between two consecutive STEP pulses must be 12 msec minimum (see Fig. 2 - 17). As long as WRITE GATE / or WRITE INHIBIT is active during a write operation the STEP pulse interface line is inhibited in the input interface logic.

I N					O U T				
STEP	PHASE	A/	B/	C/ D/	STEP	PHASE	A/	B/ C/	D/
-		L	H	L H	-		L	H L	H
1		H	L	L H	1		L	H H	L
2		H	L	H L	2		H	L H	L
3		L	H	H L	3		H	L L	H
4		L	H	L H	4		L	H L	H

TABLE 2 - 4 . SEQUENCE OF THE STEPPER MOTOR SIGNALS

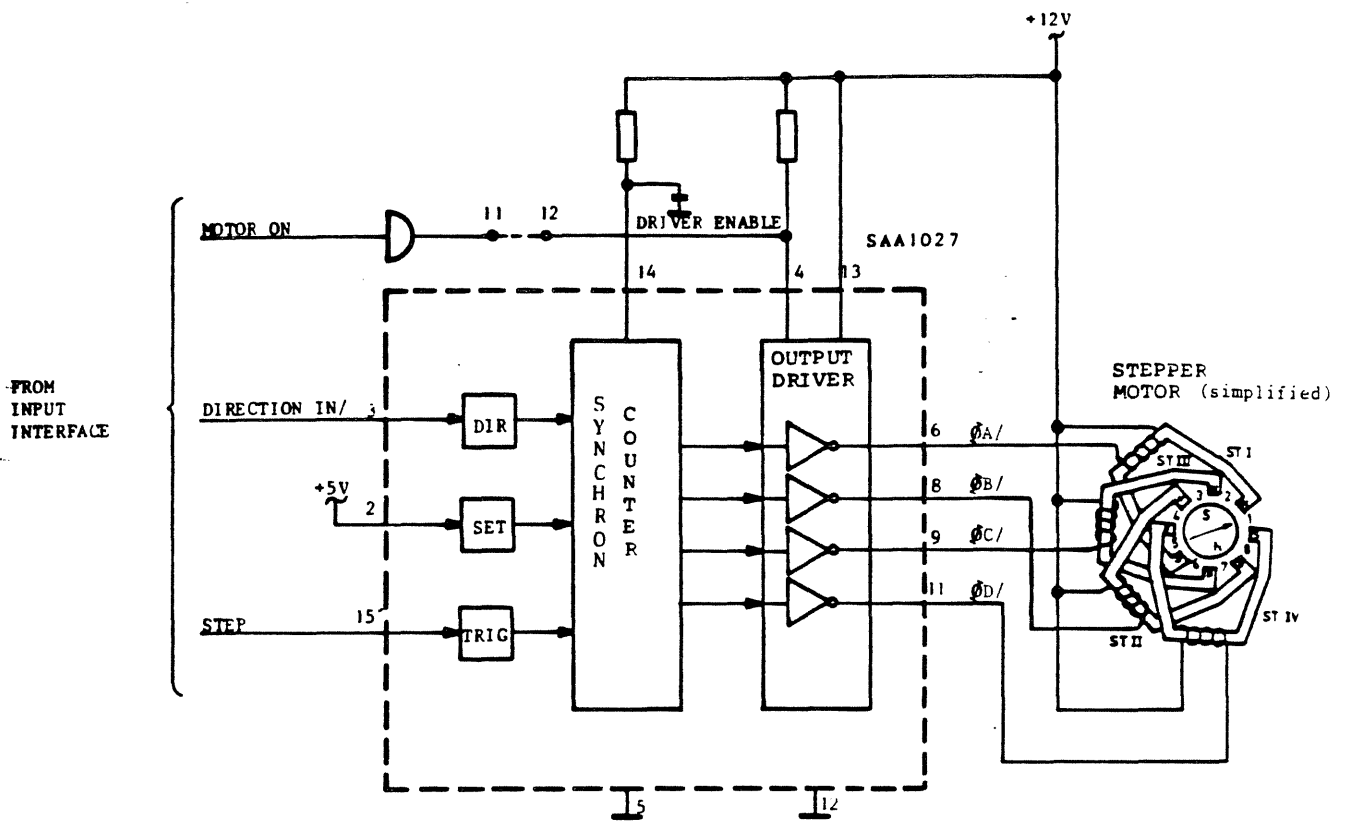

FIGURE 2 - 16 . STEPPER MOTOR CONTROL

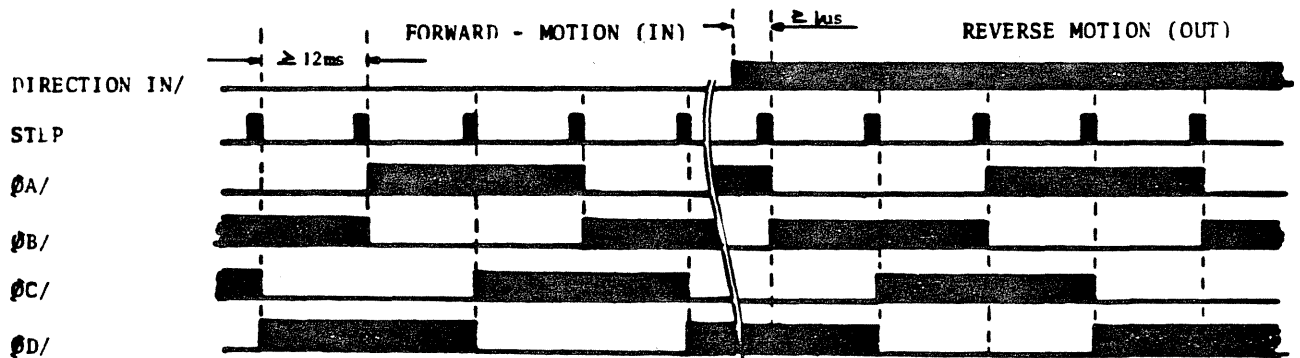

FIGURE 2 - 17 . STEPPER MOTOR - TIMING DIAGRAM

### 2.2.3. DRIVE MOTOR CONTROL (Fig.2 - 18)

The drive motor used in the BASF 6106 is a DC-motor. Start and stop of the motor is controlled from the host system by the interface signal MOTOR ON. After the drive motor is started, a delay of 0,5 sec is needed to allow proper motor speed, before reading or writing. The speed of the drive motor is controlled by the integrated circuit ESM 227. This IC holds the EMF of the drive DC-motor to a constant value. Because the speed of the drive motor is proportional to it's EMF, the

speed will be also constant. With the potentiometer R40 the drive motor must be adjusted to 300 RPM. The output voltage of the ESM 227 is controlled by the MOTOR ON/-signal at Pin 12 of the chip. If MOTOR ON is inactive (low) T1 will be closed and holds T2 open. The drive motor stops. An active MOTOR ON - signal opens T1 and T2 is enabled. The drive motor is running and regulated, so that the mini disk is rotatiting at 300 rpm.

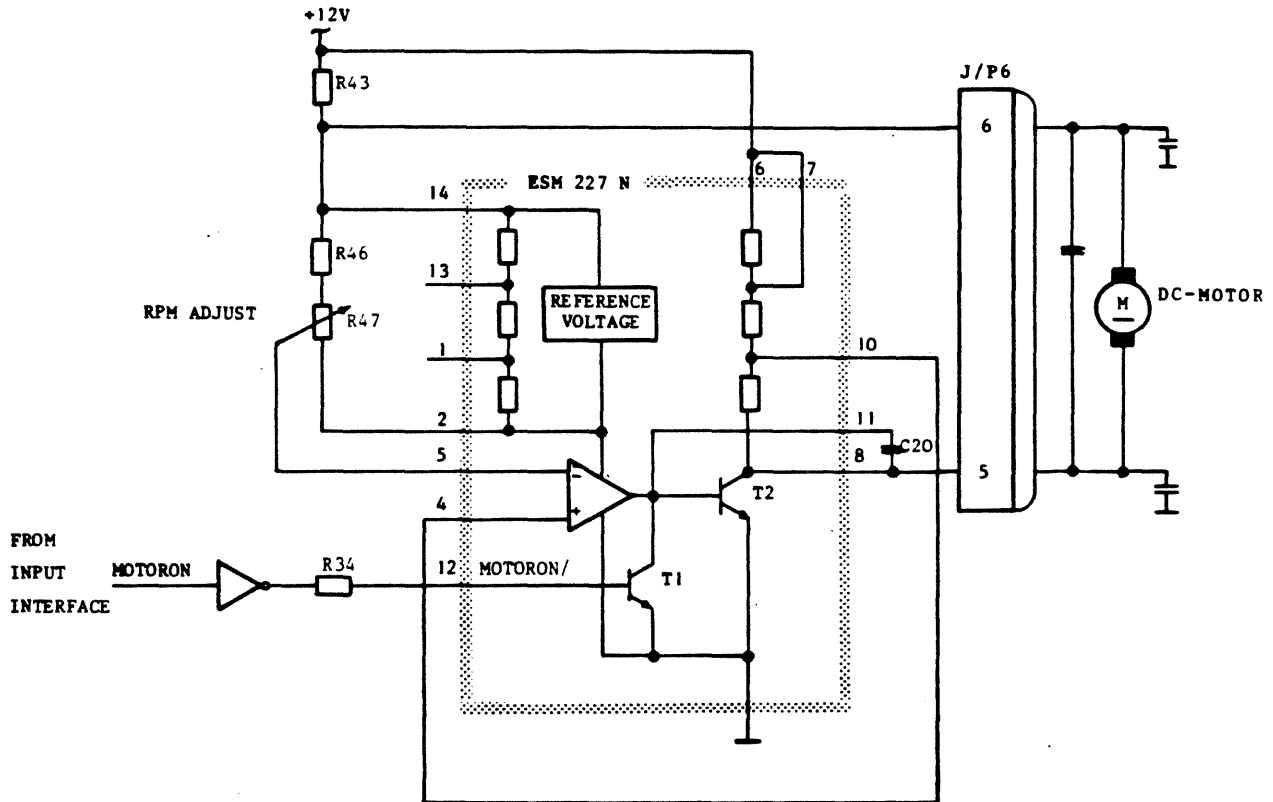

FIGURE 2 - 18 . DRIVE MOTOR CONTROL



2.2.4. HEAD LOAD LOGIC (Fig.2 - 19 )

The head load mechanism is activated by the head load solenoid. This solenoid is energized when HEAD LOAD ENA/ is active and the mini disk is up to speed (SPEED → high). SPEED is activated by the speed detection logic. As the head load solenoid is activated, Transistor T1 is closed for 20 ms by the 20 ms One Shot, to supply sufficient starting current for the head load solenoid (see timing diagram Fig. 2-20 ). If the HEAD LOAD ENA/ signal is deactivated or the front door is opened (SPEED → low) because mini disk isn't

turning.) The head load solenoid will drop and the head is unloaded.

For the door lock solenoid and the activity LED two SN 75453 drivers are used. The activity LED driver is enabled by SPEED of the ready detector circuit. The activity LED can be turned on if the head is loaded (HEAD LOAD ENA active) or if the door lock solenoid is activated (see 2-20 ). The door lock solenoid is activated if HEAD LOAD ENA or I/O ENA or DOOR LOCK ENA is active (see 2-20 ).

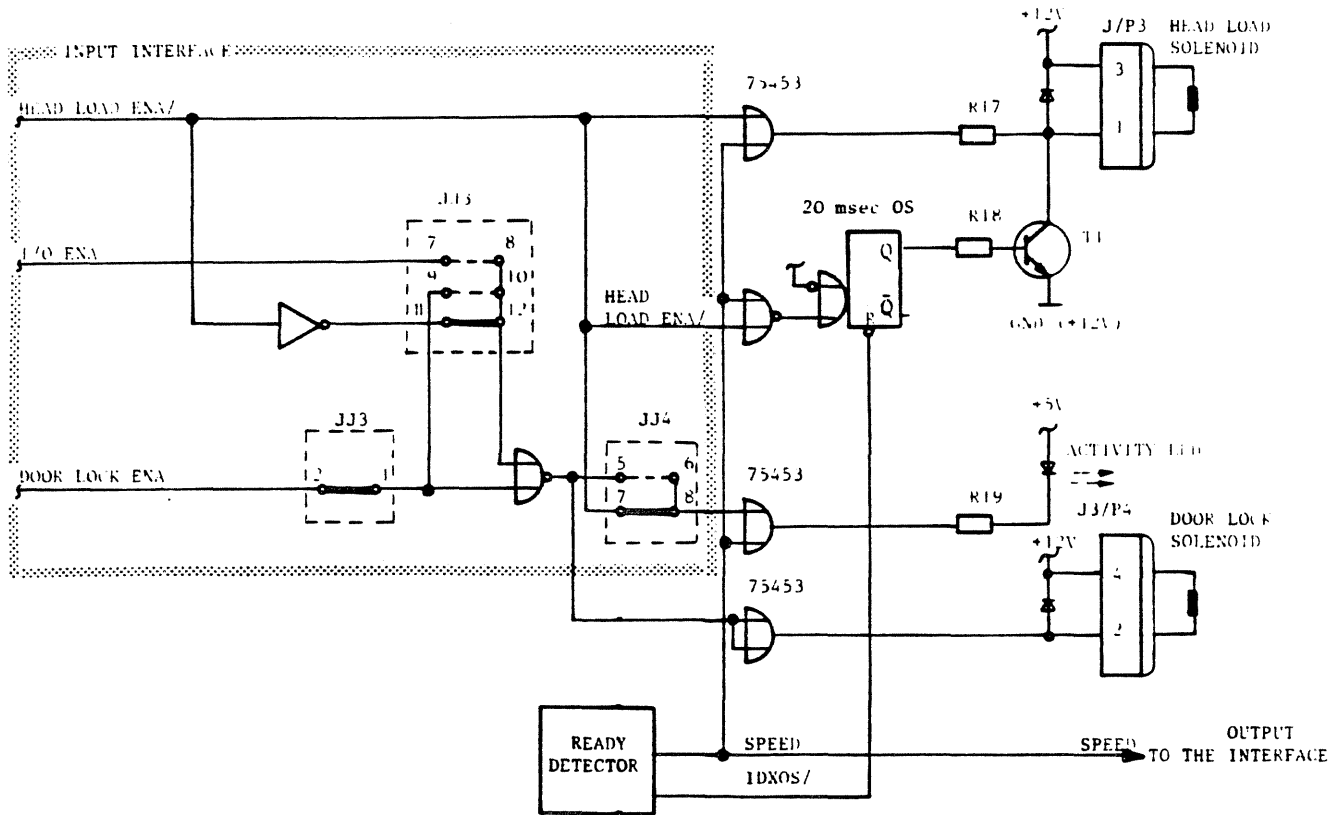

FIGURE 2 - 19 . HEAD LOAD CIRCUIT DOOR LOCK SOLENOID AND ACTIVITY LED DRIVER

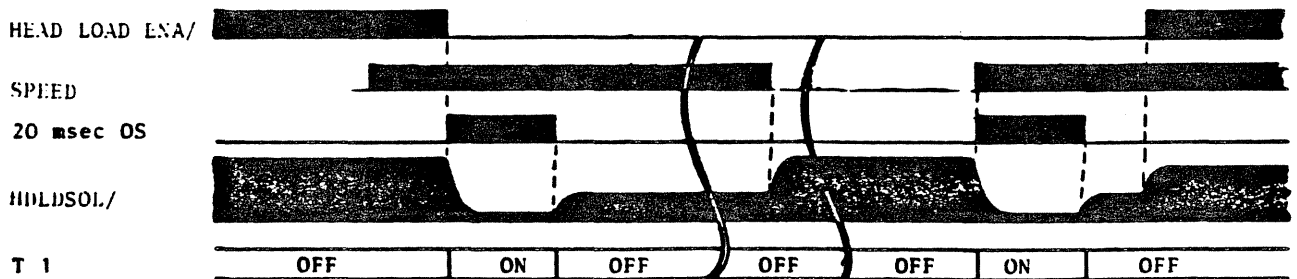

FIGURE 2 - 20 . HEAD LOAD - TIMING DIAGRAM

### 2.2.5. TRACK ZERO DETECTOR

This logic generates the TRACK 00 signal when the read/write head is positioned at track zero. The host system uses this signal to recalibrate the positioning system. When the position of the read/write head is unknown the host system sends step out pulses until TRACK 00/ goes low.

The track zero detector comprises a micro-switch, a debounce circuit and a phase comparator circuit (see Fig. 2-21) and is activated by the head carriage. When the head carriage moves out the track zero switch must be open before the read/write head reaches track four. When the head carriage moves towards the track zero position the microswitch must close after track four and before track zero. The TRACK ZERO signal will be active when

the track zero switch is closed and phase A and phase C of the stepper motor are activated. OUTENABLE (O ENA) must be high. Fig 2 - 22 shows the corresponding timing diagram when the host system tries to step the head carriage out of track zero. The mechanical stop at the spiral wheel prevents the read / write head from moving out further and holds it near track zero. The TRACK 00/ signal will be deactivated, because the stepper motor is in a wrong phase ( $\phi B$  and  $\phi C$ ). If the host system sends three more step out pulses, the phase of the stepper motor is correct again, the TRACK 00 signal is again activated and the read/write head is positioned at track zero.

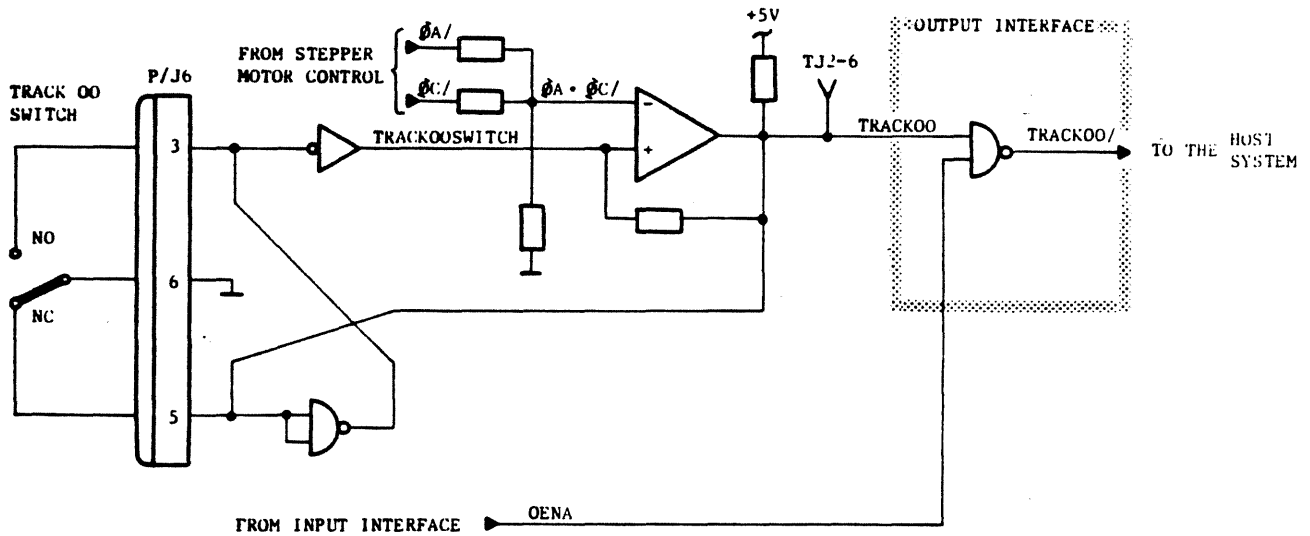

FIGURE 2 - 21 . TRACK ZERO DETECTOR

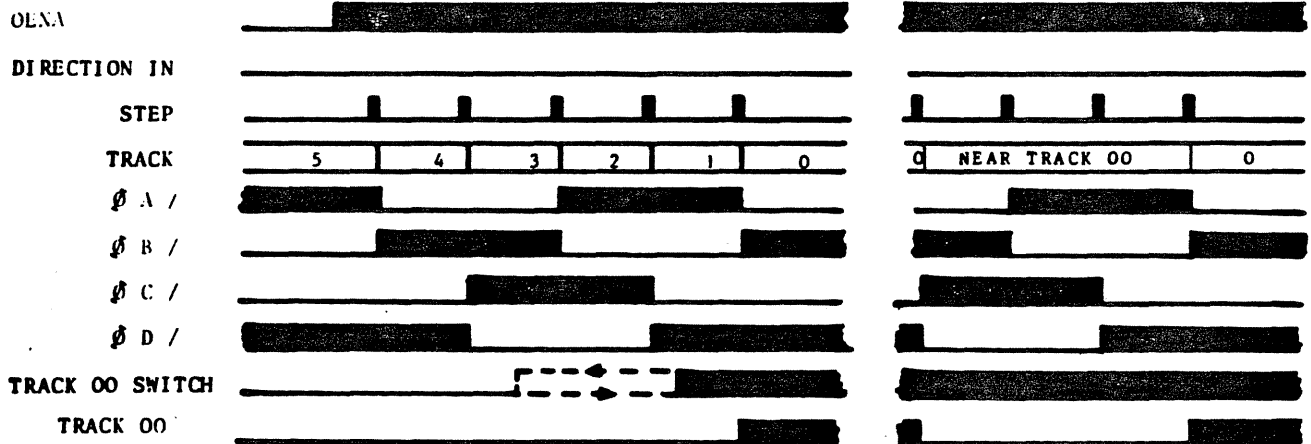

FIGURE 2 - 22 . TRACK ZERO - TIMING DIAGRAM

### 2.2.6. WRITE PROTECT DETECTOR

The write protect detector is implemented like the index detector. (see Fig.2 - 23) A LED and a photo transistor is used with a comparator circuit to detect the write protect notch in the mini disk. When a " write protected " mini disk (write protect notch not covered ) is inserted, the photo transistor will sense the light of the LED causing the negative input to the comparator to go low and the output of the comparator " NOTCH OPEN " will be high. The setting of the write protect jumpers decides whether writing is allowed or not (see Table ). If INHIBIT WRITE is high, the WRITE ENABLE- signal is disabled. The mini disk drive is now unable to write, even if the host system will activate the WRTGATE/ inter-

face line. The WRITE PROTECT/- signal is send to the host system when OUTENABLE is high. The WRITE PROTECT- line informs the host system, that a write protected mini disk is inserted. If a nonprotected mini disk is inserted, WRITE PROTECT/ will be inactive and write operations are allowed.

JUMPER	NOTCH COVERED	NOTCH OPEN	REMARKS
JJ3: 3÷4	unprotected	protected	ECMA-NORM
JJ3: 5÷6 JJ4: 3÷4	protected	unprotected	Shugart

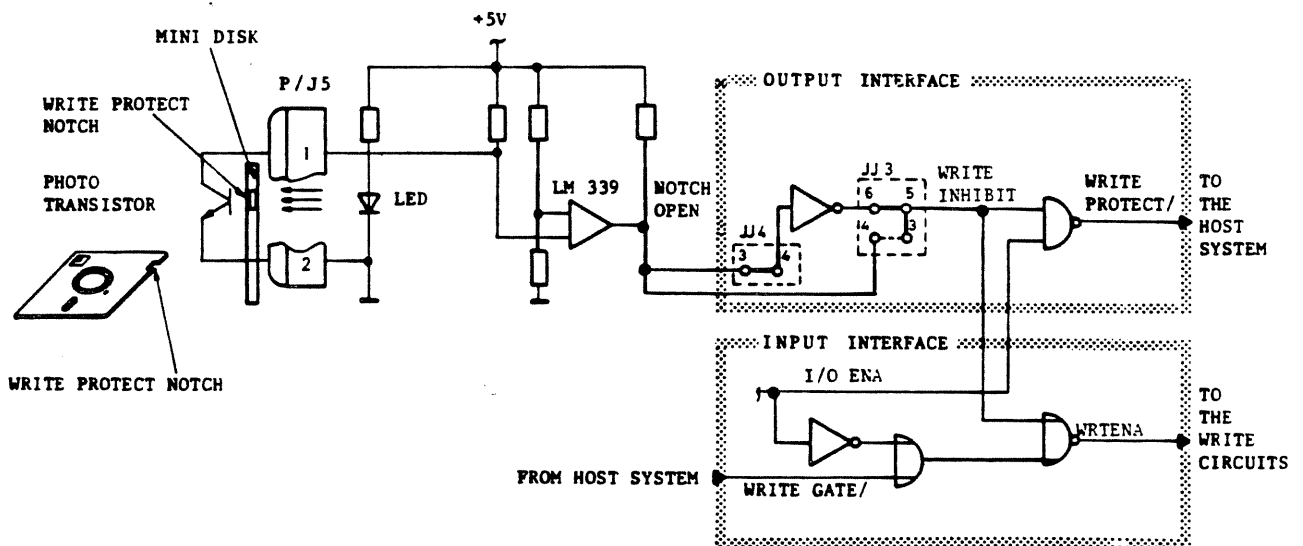

FIGURE 2 - 23 . WRITE PROTECT DETECTOR

## 2.2.7. INDEX/SECTOR- and READY DETECTOR

### 2.2.7.1. INDEX/SECTOR DETECTION

The index/sector detector comprises a photo transistor mounted on the deck assembly, a light emitting diode (LED) on the PWB and a comparator (see Fig. 2-24 ). As the index hole or sector (optional) hole passes between LED and phototransistor, light from the LED is passes to the phototransistor. This results

in a negative pulse of about 1,5 msec on the inverting input of the comparator. The output pulse of the comparator is sent to the host system by the output interface when I/O ENA is activ. Also the INDEX- pulse is used as input signal for the ready detector logic.

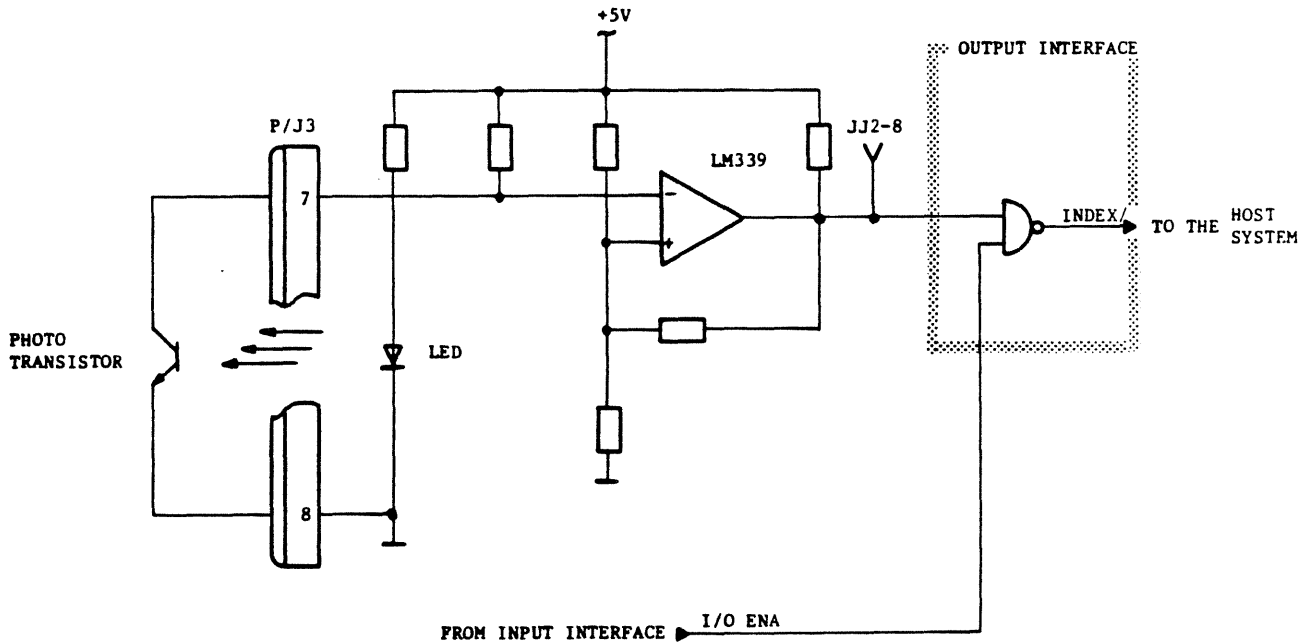

FIGURE 2 - 24 . INDEX DETECTOR

2.2.7.2.READY DETECTION

The ready detector (Fig. 2 - 25) is used to monitor the INDEX pulses for the rotational speed of the disk. The INDEX-pulses are input to the 300 msec hold-over-one shot. When the time between two consecutive INDEX-pulses is greater than 300 msec, the index counter is held reset. If the time is less than 300 ms

the hold over one shot is held fired and enables the index counter. After two consecutive INDEX-pulses are clocked the index counter SPEED is high and the READY/signal is sent to the host system.

(see timing diagram Fig. 2 - 26)

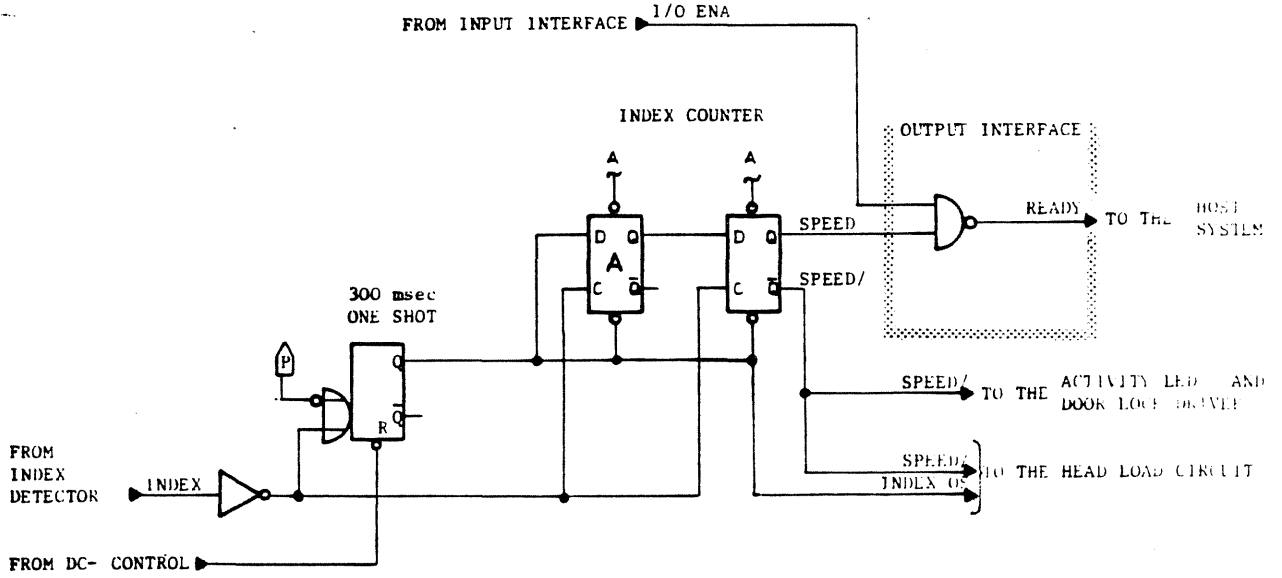

FIGURE 2 - 25 . READY DETECTOR

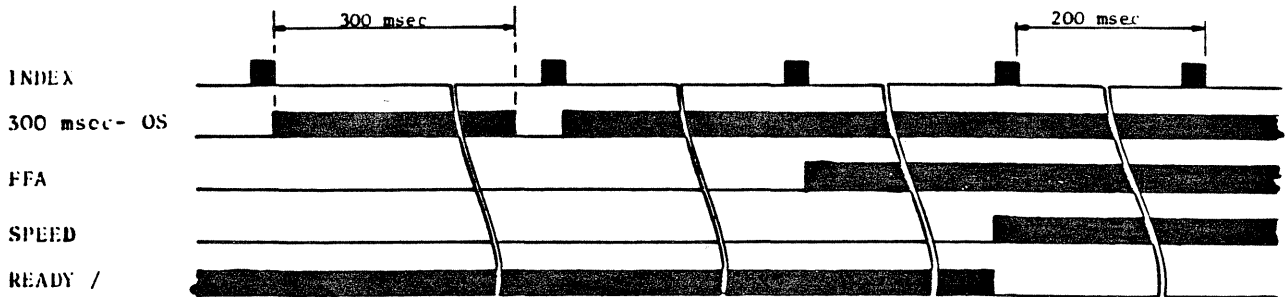

FIGURE 2 - 26 . READY TIMING

## 2.2.8. READ/WRITE CIRCUITS

### 2.2.8.1. READ/WRITE HEAD

The read/write head used in the BASF 6106 is a tunnel erase type ceramic head. It records and reproduces data at a flux density of 3536 to 5536 flux changes per inch (fci)

The nominal frequency measured on the read/write head for an "all 0's" pattern is 62,5 kHz and 125 kHz for an "all 1's" pattern when FM recording technique is used. The nominal time between flux reversals is 8  $\mu$ sec (all 0) or 4  $\mu$ sec (all 1). The radial density is 48 tracks per inch (tpi). This gives 0,0208 inch nominal track to track spacing. The tunnel erase gaps trim the track width to 0,014 inch after write and to 0,012 inch after erase (see Fig. 2 - 27 ).

The read/write head contains three coils: two read/write coils and the erase coil (see Fig. 2-28 ). The erase coil is energized

during every write operation and limits the track width and provides low noise guard bands on each side of the recorded track. The two read/write coils are wound on a single core and are center tapped. The electrical connections of the read/write head are shown on fig. 2 - 28 . During a write operation each bit written will be directed alternately to one of the two read/write coils by a flipflop. This causes a flux change for every bit to be written. The old data on the track will be overwritten by the new data stream. On a read operation an output voltage is induced in the read/write head by every flux change that passes the gap of the read/write head. This voltage is used by the read circuits to recover the written data.

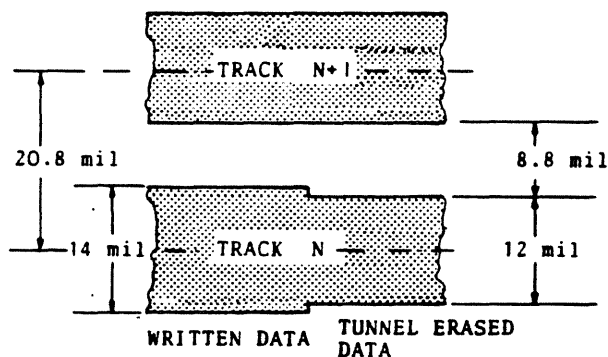

FIGURE 2 - 27 . TRACK GEOMETRY

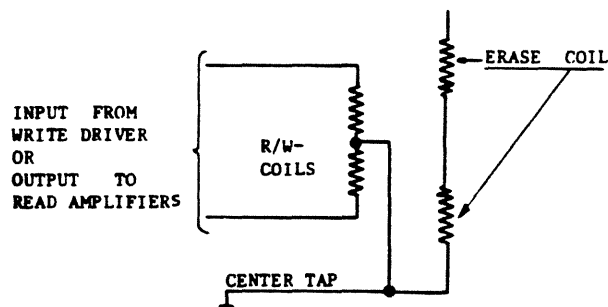

FIGURE 2 - 28 . ELECTRICAL CONNECTION OF THE READ/ WRITE HEAD

### 2.2.8.2.WRITE CIRCUITS

The write circuits encode serial data from the host system to magnetic flux patterns recorded on the mini disk. A write operation is initiated by the host system activating the following input lines (see Fig. 2 - 29 ).

- SELECT/ selects the drive and loads the head if no head load option is installed.
- MOTOR ON / rotates the mini disk.
- WRITE GATE / turns on the write circuits.
- WRITE DATA / FM-encoded write data.
- HEAD LOAD / loads the head if head load option is used.

A simplified logic of the write circuits is shown on Fig. 2-30 . The write circuits are activated by WRTENA which is active when the host system sends WRITE GATE. The drive must be selected and not write protected. The FM data stream from the host system is divided by the write flipflop. The outputs of the write flipflop alternately turn on transistor T3 and T4 (see Fig. 2-31 ). The write current  $I_w$  respectively  $I_w'$  which is determined by the resistor R35 flows then alternately through the windings  $W_1$  and  $W_2$ . The write current and erase current can be blocked by the DC- control logic, if a power failure have been detected. The erase current  $I_3$  is turned on by transistor T5 when ERASENA/ is low.

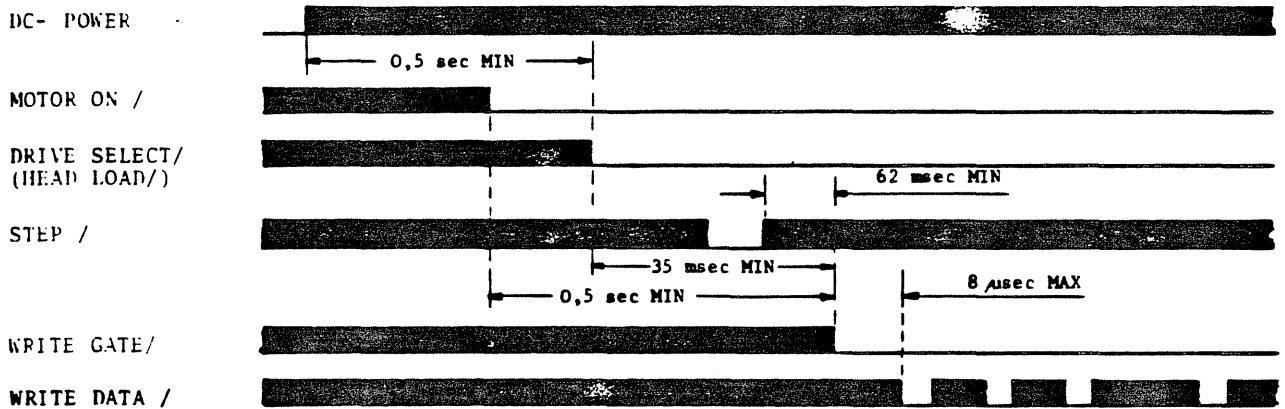

FIGURE 2 - 29 . WRITE INITIATE TIMING

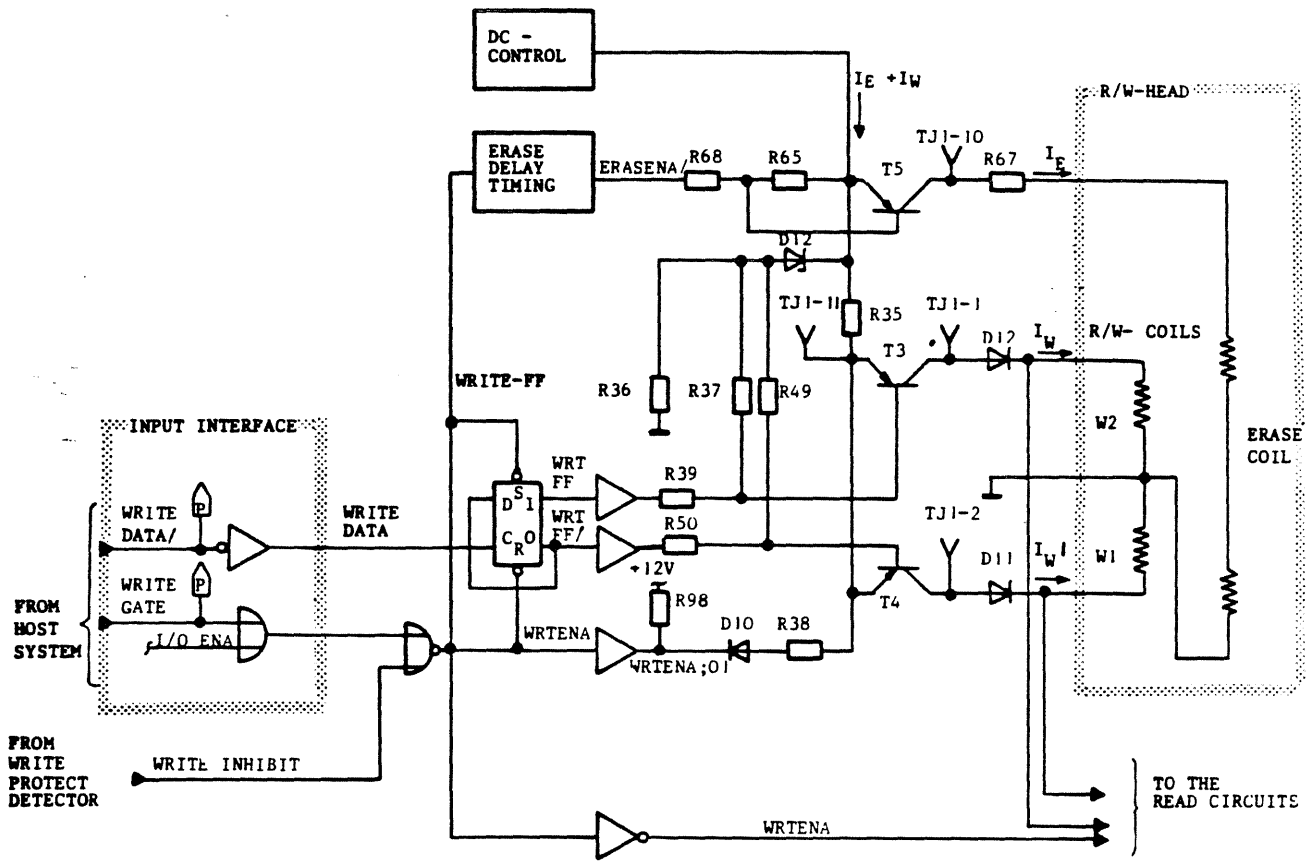

FIGURE 2 - 30 . SIMPLIFIED WRITE CIRCUITS

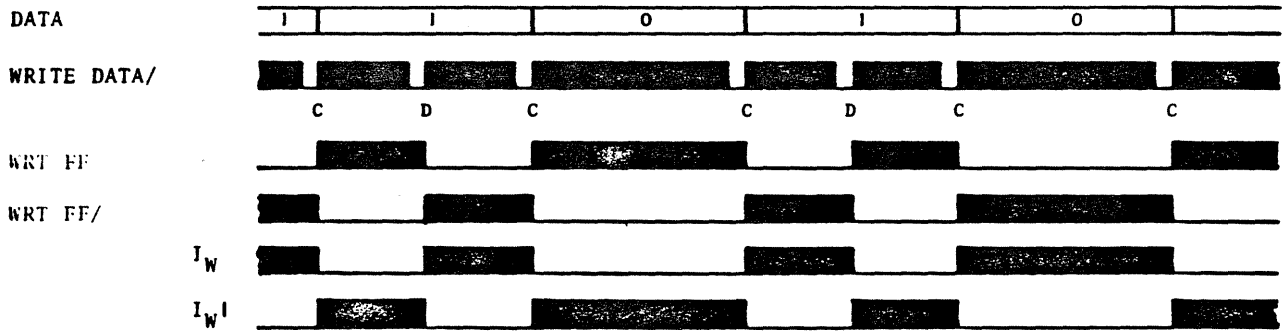

FIGURE 2 - 31 . TIMING DIAGRAM WRITE OPERATION (SIMPLIFIED)



ERASENA/ is switched always a certain delay time after WRITE GATE/. The value of the erase current is determined by the value of the resistor R67. The delay of the erase current is necessary, because the tunnel erase gaps are physically located behind the read/write gap. This causes the erase gap to reach the same place on the track always later than than the read/write gap. Fig.2 - 32 shows the logic of the the erase delay logic. Fig. 2 - 33 is a timing diagram for the erase delay logic.

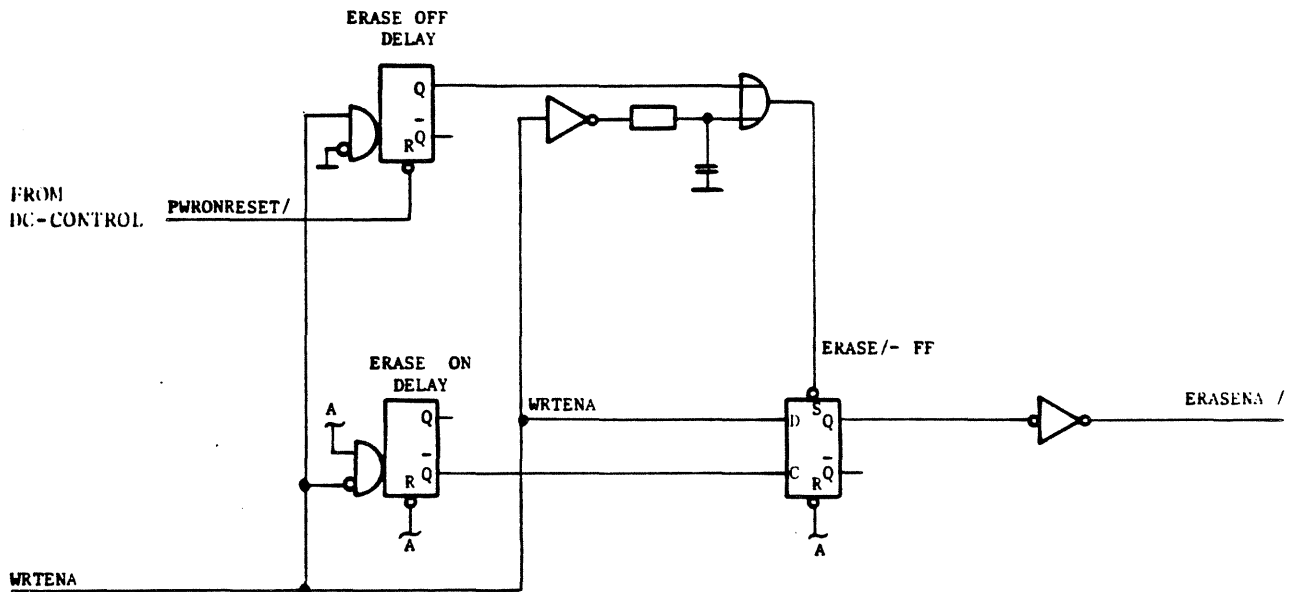

FIGURE 2 - 32 , ERASE DELAY LOGIC

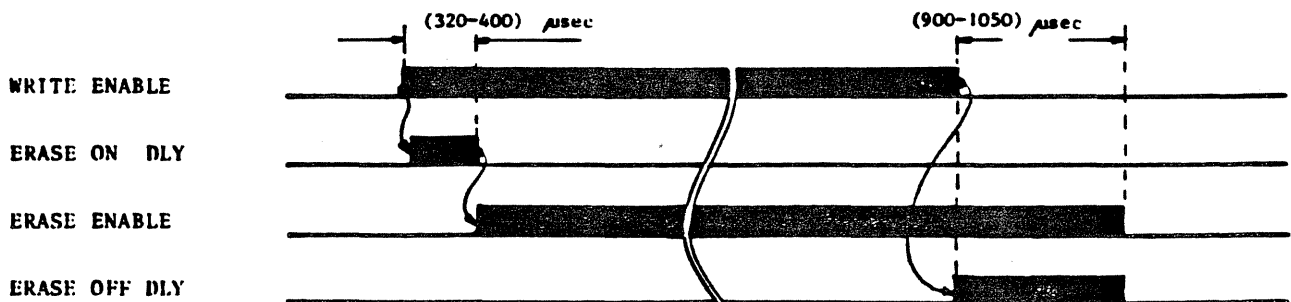

FIGURE 2 - 33 . ERASE DELAY TIMING

2.2.8.3.READ CIRCUITS

The read circuits recover data recorded on the mini disk by a write operation. A read operation is initiated from the host system by activating the following lines:

- SELECT / selects the drive and loads the head if no head load operation is used.
- MOTOR ON/ rotates the mini disk.
- HEAD LOAD/ loads the head if head load option is used.

The signal WRITE GATE/ must be inactive to enable the read circuits. Fig. 2 - 35 shows the read initiate timing. The read circuits shown on Fig. 2 - 34 . Comprises a integrated read amplifier system and the necessary external components.

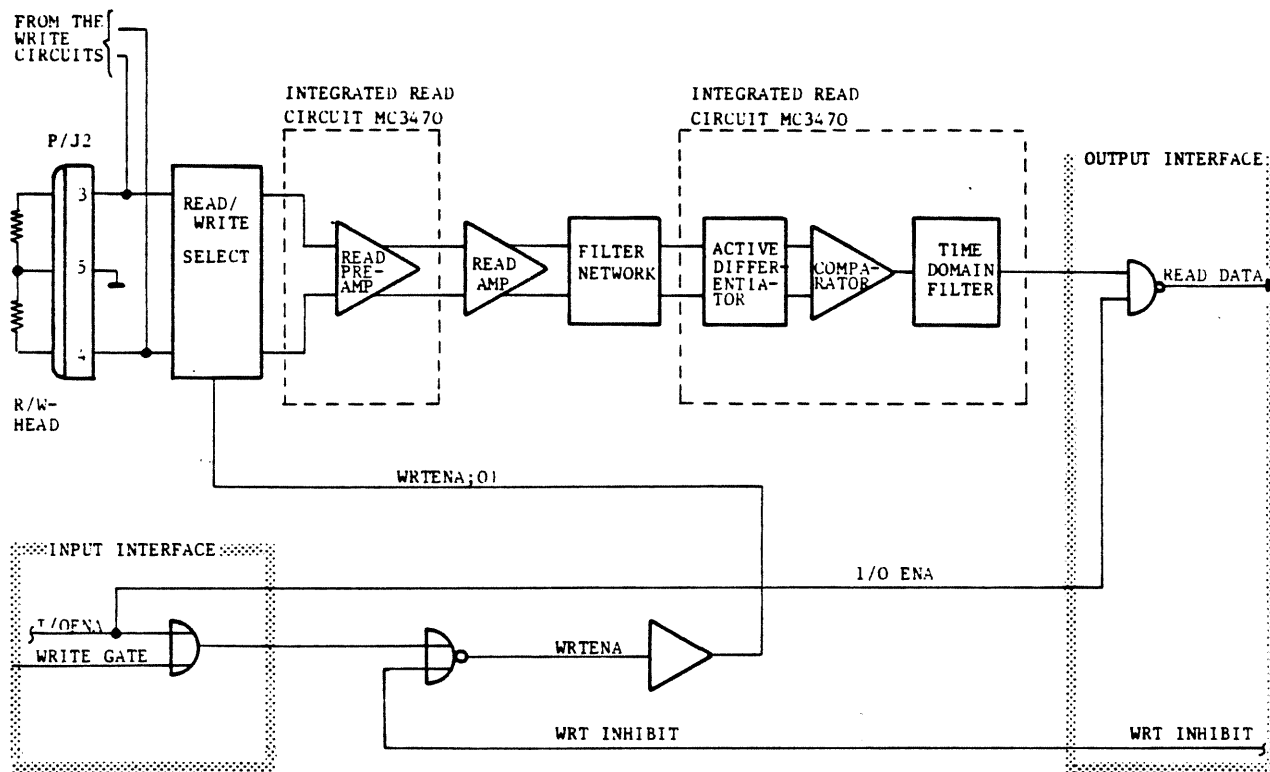

FIGURE 2 - 34 . READ CIRCUITS (SIMPLIFIED)

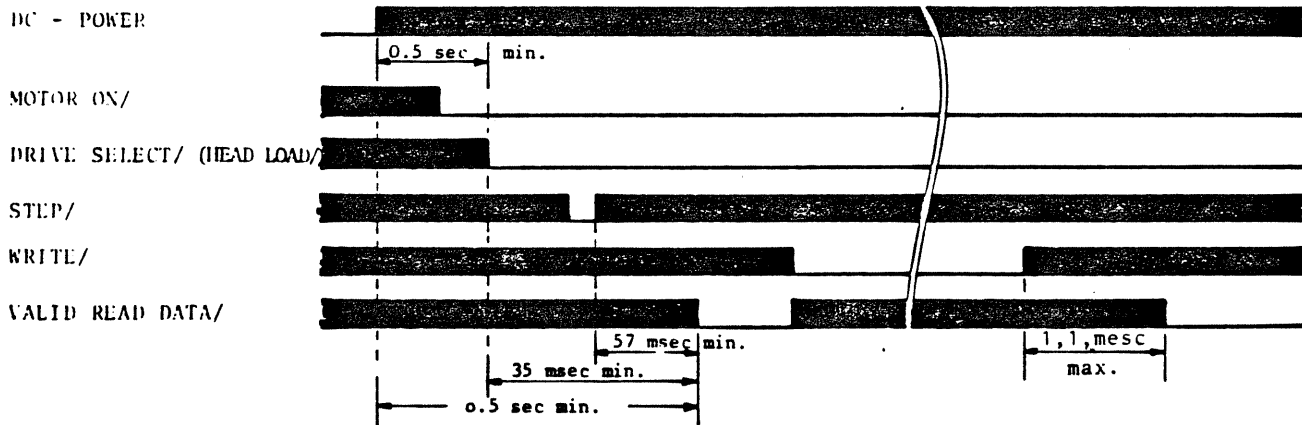

FIGURE 2 - 35 . READ INITIATE TIMING

### READ/WRITE SELECT

The read/write select circuit comprises two MOS-FET switches. The inputs of the switches are connected to the read/write coils of the read/write head. The output of the switches are connected to the read preamplifier (see Fig. 2 - 56).

When the disk drive is operating in the WRITE-mode, WRTEA;01 is high and T6 and T7 are open. The read/write coils are isolated from the read preamplifier. In the Read-mode (WRTEA;01 → low) the output signal of the selected read/write head is switched to the read preamplifier.

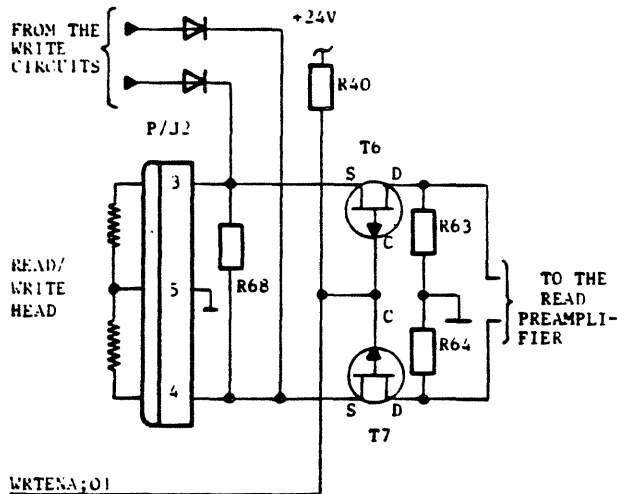

FIGURE 2 - 56 . READ/ WRITE SELECT LOGIC

### READ AMPLIFIERS AND FILTER NETWORK (Fig. 2 - 37)

For amplification of the read signal a high gain linear amplifier of the read LSI and an external transistor stage are used. Both circuits increase the read signal amplitude by a gain of ~ 300.

This amplified signal is used to drive a filter network. The filter network is a low pass filter with a bandwidth of ~ 400 kHz.

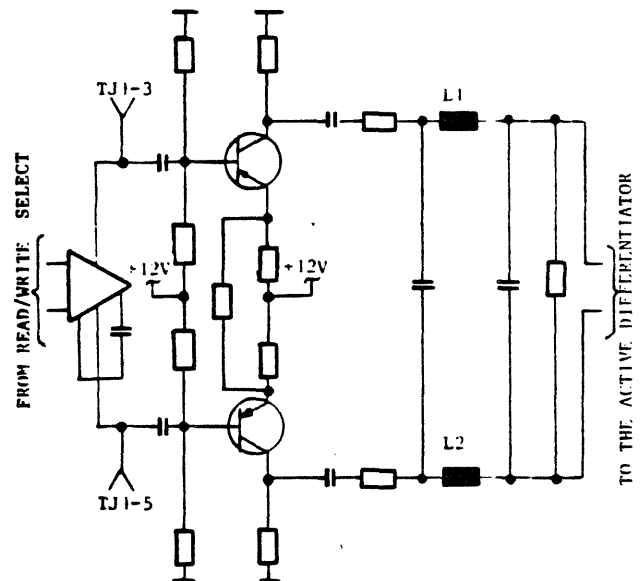

FIGURE 2 - 37 . READ AMPLIFIERS AND FILTER NETWORK

Both circuits are part of the read LSI MC3470. A simplified circuit is shown on Fig. The active differentiator is implemented by a differential amplifier with coupled emitters by a capacitor. The current through this capacitor and also through the collector resistor will be a derivative of the input voltage.

$$I_C = C \cdot \frac{dV_{in}(t)}{dt}$$

Also the output voltage  $V_o$  of the differential amplifier will be a derivative of the input voltage.

$$V_o = 2 R \cdot I_C = 2 R C \frac{dV_{in}(t)}{dt}$$

The output voltage  $V_o$  is applied to the comparator which provides zero crossing detection of the waveform. Since the capacitor shifts the current  $\sim 90^\circ$  to the input voltage peak detection of the input voltage is performed. Fig. 2-40 shows a timing diagram of the differentiator and comparator circuit.

The purpose of the time domain filter is to suppress false crossovers of the comparator caused by shouldering in the differentiated read signal. This can happen on outer tracks of high resolution disks when high resolution heads are used. The time domain filter comprises a puls generator, the time domain one shot and the time domain flipflop ( see Fig. 2-39 ) and is part of the integrated read LSI. The puls generator generates a short pulse for every transition on its input. These pulse are used to trigger the time domain one shot. The pulse duration of the time domain one shot is determined by an external RC-combination and is set to 2 usec for the BASF 6106. The state of the comparator output is loaded into the time domain flipflop by the trailing edge of the time domain one shot 2 usec later (see Fig. 2-40 ). Because false zero crossings always exists for a shorter time, the time domain flipflop will not change when it is clocked by false crossovers. The crossover detector consists of a bidirectional one shot which is triggered by each transition of the time domain flipflop. The pulse wide of the crossover detector can be adjustet by external elements. For the BASF 6106 the output pulses (READ DATA/) of the crossover detector are set to 500 nsec.

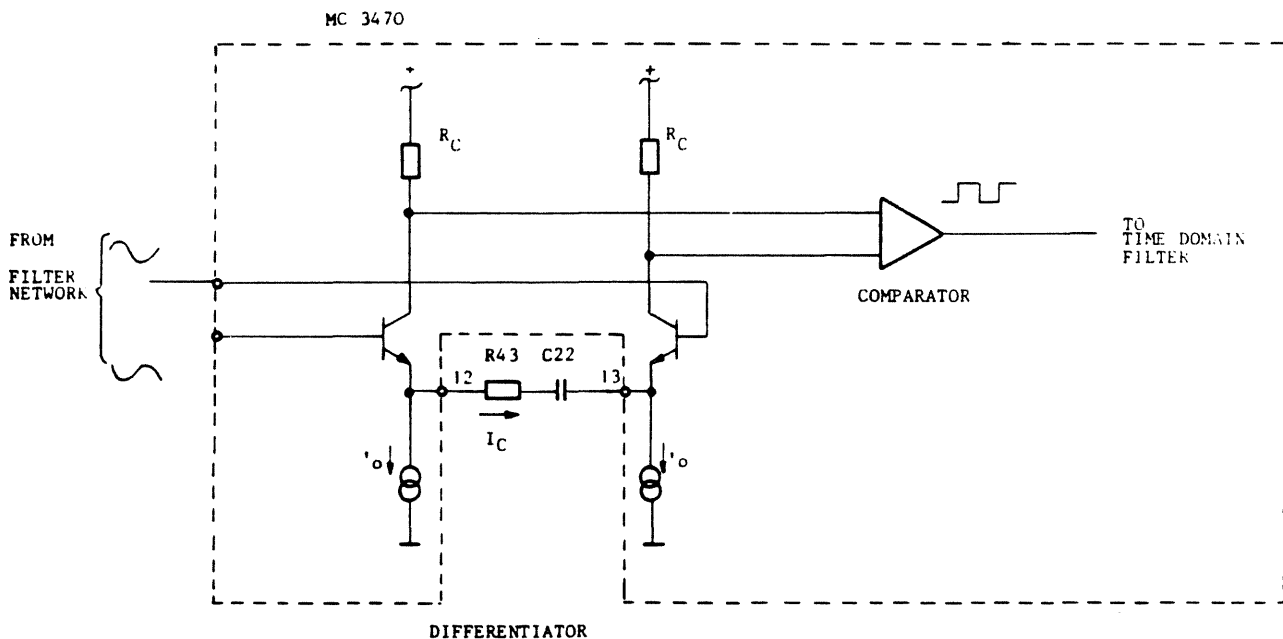

FIGURE 2 - 38 . ACTIVITY ACTIVE DIFFERENTIATOR AND COMPARATOR

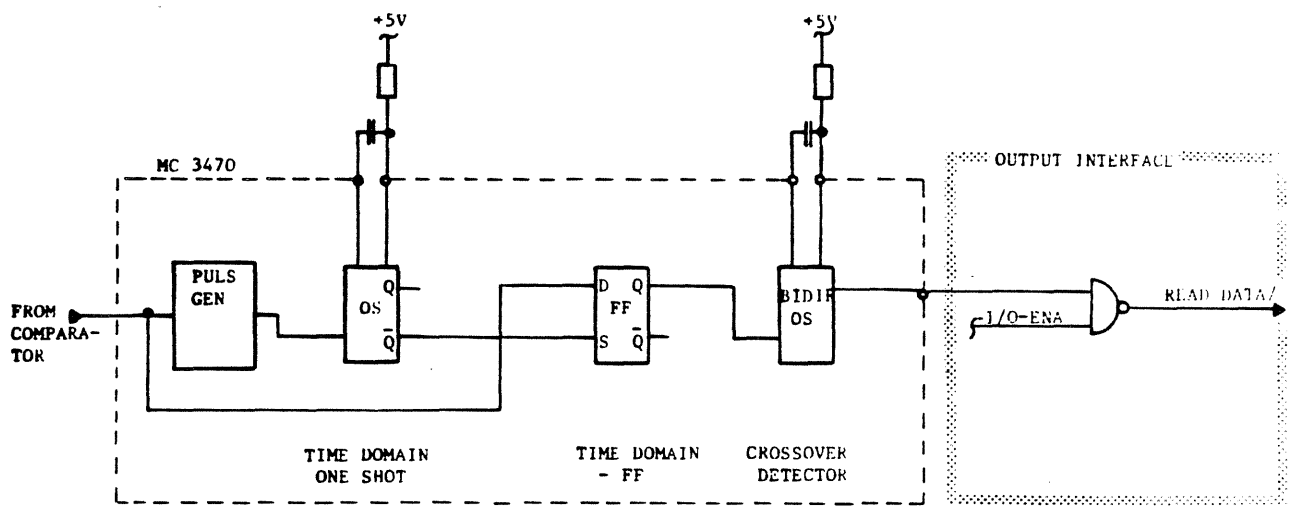

FIGURE 2 - 39 . TIME DOMAIN FILTER AND CROSSOVER DETECTOR

Timing Diagram Read Circuits

Fig. 2 - 40 is a timing diagram of the whole read circuit and illustrates the function of the different parts.

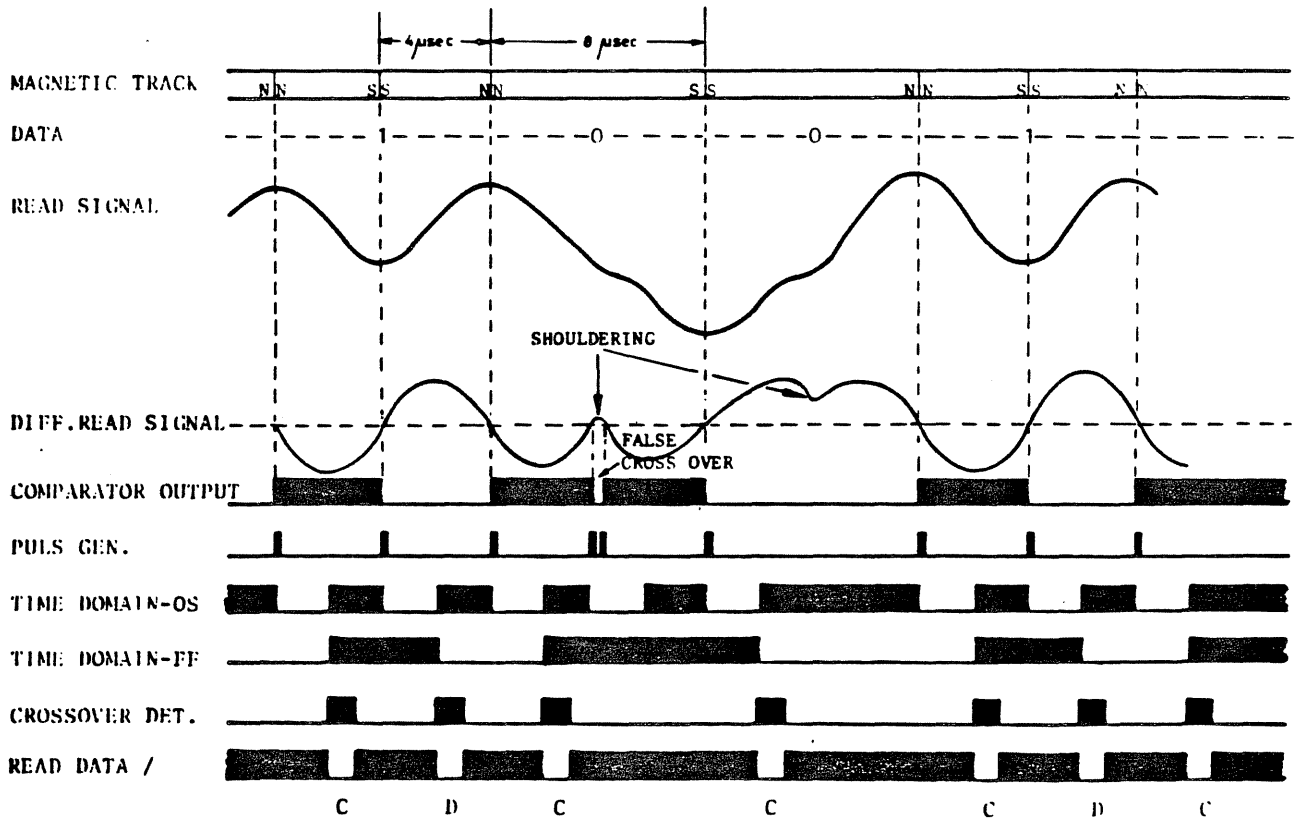

FIGURE 2 - 40 . TIMING DIAGRAM READ CIRCUITS

2.2.9. DC- CONTROL AND POWER ON RESET LOGIC

2.2.9.2.POWER ON RESET LOGIC

2.2.9.1.DC- CONTROL

The DC- control logic is shown on Fig. 2-41 . This logic monitors the DC- voltages + 5 V and + 12 V and disables the write and erase current source, if one of these voltages is missing or out of the following limits:  
 If + 5 V falls below + 4,7 V , DC - CONTROL goes high and disables T3.  
 If + 12 V falls below 9 V ,T3 is also blocked and the write and erase current inhibited.

The power on reset logic is shown on Fig. 2-42 . As the +5V energizes the capacitor begins to charge towards 3 V. As long as the capacitor voltage is lower than the threshold voltage  $V_{th}$  of the driver gate the PWRONRESET /- signal is held low, thus a 40 msec logic initialization pulse is developed (see Fig. 2-43 ). The PWRONRESET/- pulse provides the following:

- Resets the ERASE OFF Delay One Shot.
- Resets the Ready Detector Logic.
- Resets the IN USE- FF.

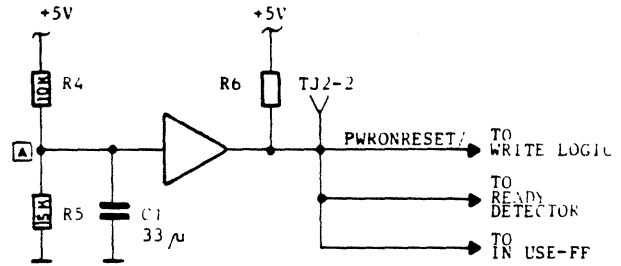
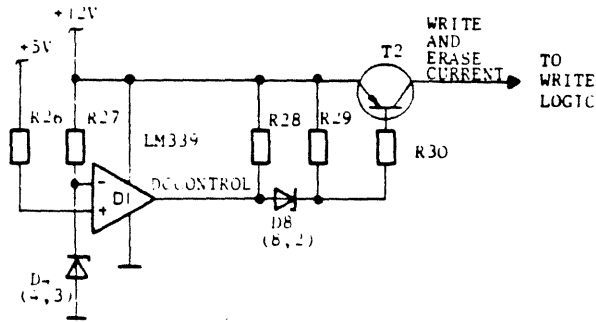

FIGURE 2 - 41 . DC- CONTROL LOGIC

FIGURE 2 - 42 . POWER ON RESET LOGIC

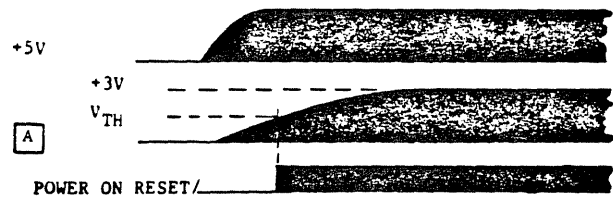

FIGURE 2 - 43 . TIMING DIAGRAM POWER ON RESET

# SECTION 3

## INSTALLATION AND OPERATION

### 3.1. INSTALLATION

#### 3.1.1. GENERAL

This section provides information for installation and configuration of the mini disk drive.

#### 3.1.2. UNPACKING AND INSPECTION

The mini disk drive is packaged in a heavy duty container, designed to ensure adequate protection during shipping and handling (see Fig. 3 - 1). When the mini disk drive is installed, store the container and all packing material for possible future use. Use the following procedure during unpacking and inspection:

- Remove contents of shipping container and inspect for in-transit damage. If damage is evident, notify the carrier and BASF. Specify nature and extent of damage.
- Verify that contents of shipping container agree with shipping list. Notify a BASF representative if anything is missing.
- Verify that model designation and serial number agree with those on the shipping invoice.
- Inspect assemblies for loose hardware. Tighten hardware if necessary.

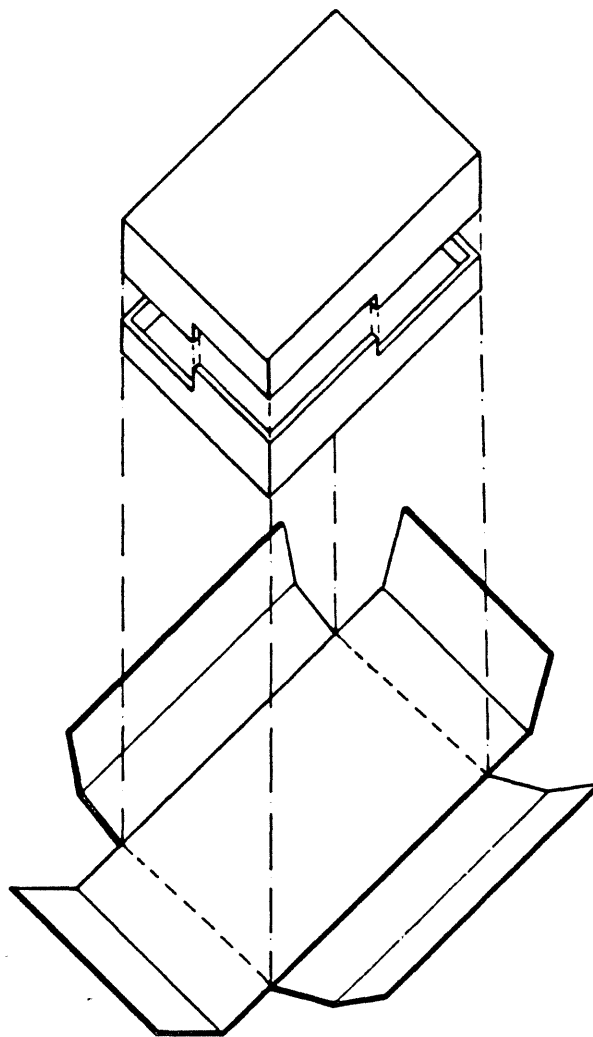

FIGURE 3 - 1 . SHIPPING CONFIGURATION

### 3.1.3. CONNECTING CABLES

The mini disk is connected to the host system by two connecting cables, the DC- cable and the interface cable. The DC- cable requires direct connection to each drive, regardless of connecting configuration. The interface cable is connected to the various connecting configurations (see 3.1.6.) and should not exceed 10 feet in length.

### 3.1.4. CONNECTORS

#### 3.1.4.1. DC- CONNECTOR

DC power is connected to the disk drive through connector J5. The input pin assignments and voltage requirements and voltage requirements are listed in table 3-1.

PIN No.	DC VOLTAGE	TOLERANCE	CURRENT	MAX. RIPPLE (p - p)
1	+ 12 V	+ - 0,6 V	* 1.75A	100 mV
2	+12V RET	-	-	-
3	+ 5V RET	-	-	-
4	+ 5 V	+ - 0,25 V	0,7 A	50 mV

\* PLUS 1,4 A MOTOR STARTING CURRENT FOR MAX. 100 msec.

Voltages to be measured on testpoints on drive PCB

TABLE 3 - 1 . DC - POWER REQUIREMENTS

The return lines for + 12V and + 5V ( pins 2 and 3) should be separate lines and must be connected together in the system. DC power input connector J5 is mounted on the component side of the PCB beside the stepper motor (see Fig. 3-9 ). The 4 pin connector is BASF P/N 88 359-001 (see Fig. 3 - 2) and is soldered directly to the PCB. The recommended mating connector is AMP P/N 1-480424-0 using pins P/N 60619-1.

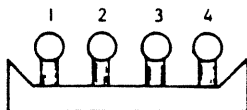

FIGURE 3 - 2 . DC- CONNECTOR

### 3.1.4.2. SIGNAL CONNECTOR

The signal cable is connected to the mini disk drive through connector J1. Connector J1 is a 34 pin PCB edge card connector located at the rear of the disk drive. The pins are numbered from 1 to 34 with the even pins on the component side. Pin 2 is located closest to the stepper motor and is labelled. A key-slot is provided between pins 4 and 6 for optional connector keying. Recommended mating connectors for J1 are listed in Table 3-2 .

CABLE TYPE	MANUFACTURER	CONNECTOR P/N	CONTACT P/N
FLAT CABLE	SCOTCHFLEX	3463-0000	NA
		3463-0001	NA
TWISTED PAIR 26	AMP	583717- 5	1-583616-1

TABLE 3 - 2 . RECOMMENDED J1 MATING CONNECTORS

#### 3.1.4.3. FRAME CONNECTOR

The mini disk drive must be frame grounded to the host system to insure proper operation . A fast on tab is provided on the drive near to the stepper motor. A fast on connector with AC ground from the host system can be attached or soldered if the mini disk drive is not fastened directly to the frame of the host system with a good AC ground. The tab is Grothe- Hartmann 17312 and its mating connector is Grothe- Hartmann 125211.

#### 3.1.4.4. INTERCONNECTING DIAGRAM

Fig. 3 - 3 is provided as an interconnecting diagram showing the connections directly to or from the PCB . Connectors J2 ÷ J6 are for internal drive use, connector J1 and J 5 are from the controller.



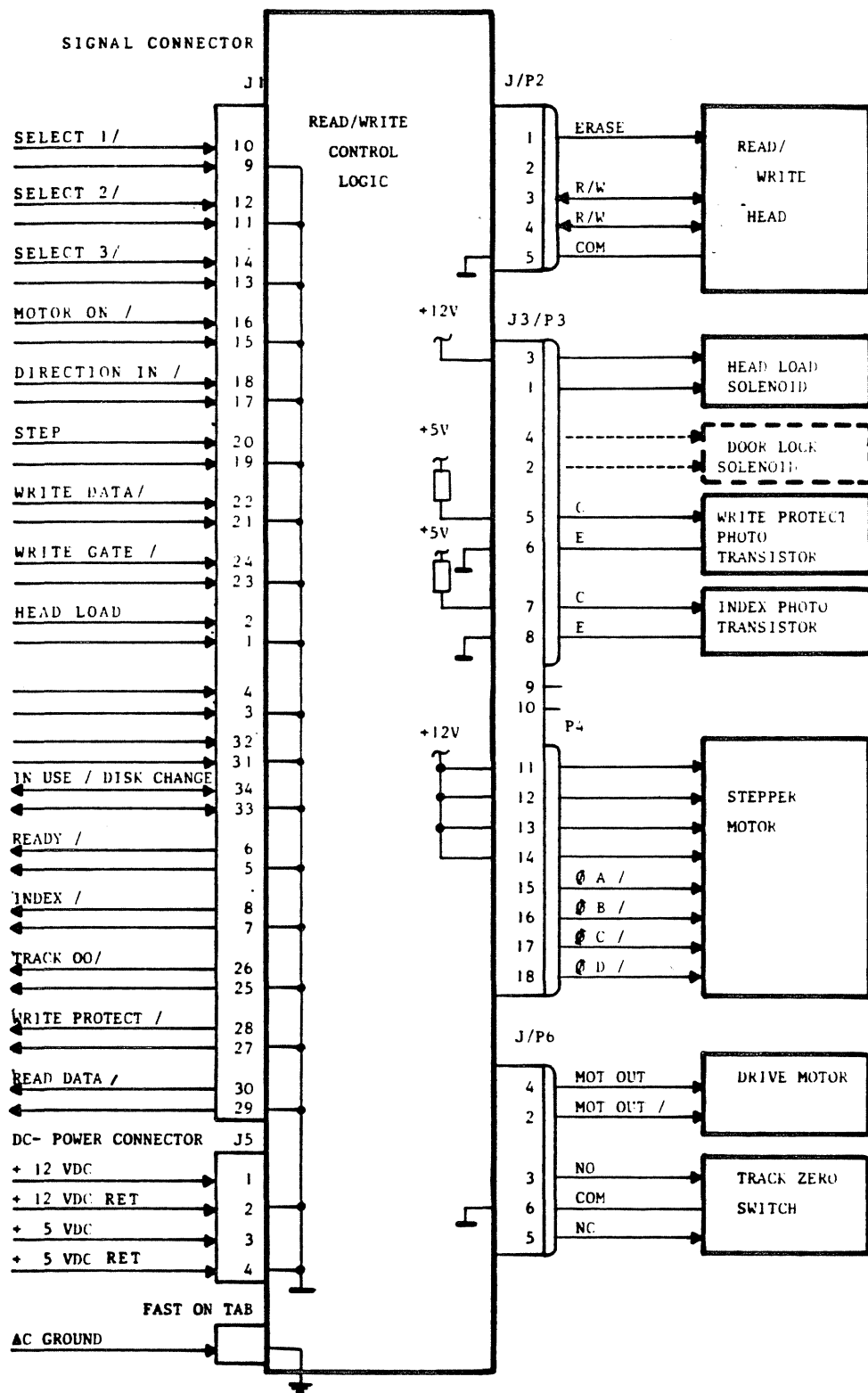

FIGURE 3 - 3 . INTERCONNECTING DIAGRAM

### 3.1.5. LOGIC LEVELS AND TERMINATION

Interface signals to and from connector J 1 have the logic levels represented by Fig. 3-4. All signal inputs are terminated by a 150  $\Omega$  resistor network chip (position 4D). This chip can be removed for a daisy chain configuration where only the last mini disk drive needs a termination network.

The BASF 6106 uses SN 7438 or equivalent as output driver. As input receiver SN 7404 or equivalent is used. Fig. 3 - 5 shows the recommended interface logic.

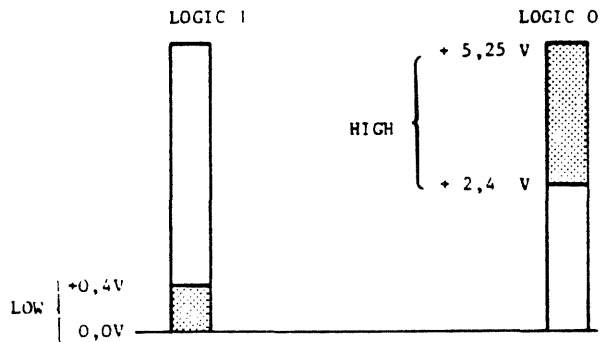

FIGURE 3 - 4 . INTERFACE LOGIC LEVELS

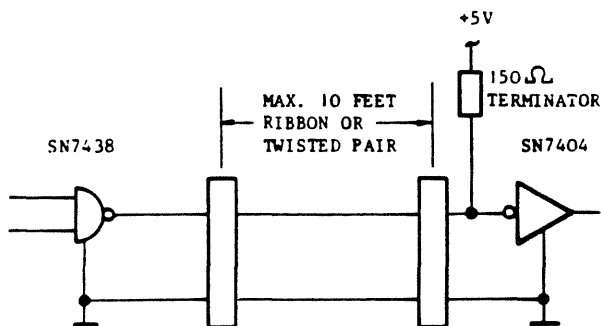

FIGURE 3 - 5 . RECOMMENDED DRIVER / RECEIVER CIRCUIT

### 3.1.6. CONNECTING CONFIGURATION

The BASF 6106 can be connected to the host system in different configurations:

- Single Drive Configuration
- Multi Drive Configuration

#### 3.1.6.1. SINGLE DRIVE CONFIGURATION

Only one drive is connected to the host system as shown in Fig. 3 - 6.

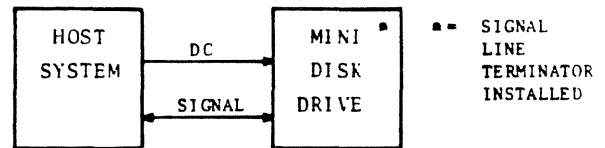
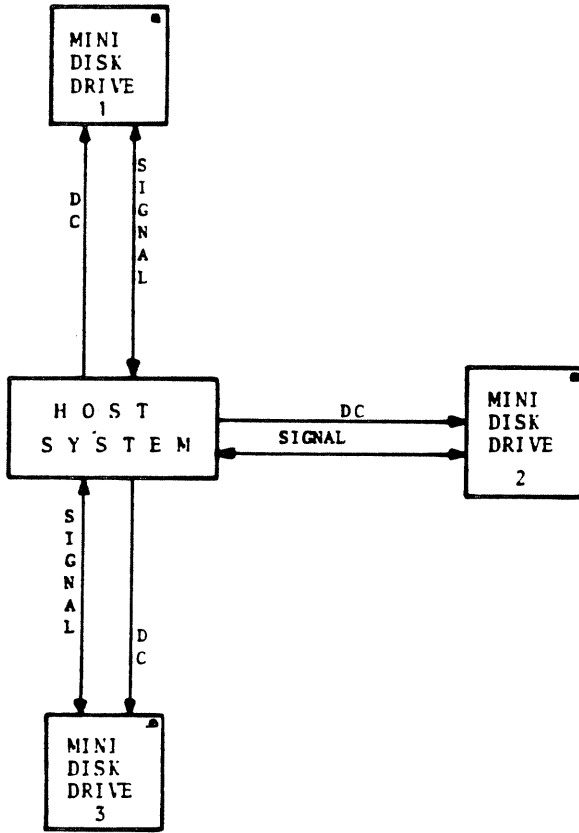

FIGURE 3 - 6 . SINGLE DRIVE CONFIGURATION

#### 3.1.6.2. MULTIPLE DRIVE CONFIGURATION

In multi drive configurations more than one drive are connected to the host system. In a multi drive configuration the BASF 6106 can be connected in radial select or daisy chain fashion (see Fig. 3 - 7 and 3 - 8).

In a radial select configuration all mini disk drives need terminator networks and in a daisy chain configuration only the last drive needs a terminator chip.



• SIGNAL LINES TERMINATOR

FIGURE 3 - 7 . RADIAL SELECT CONFIGURATION

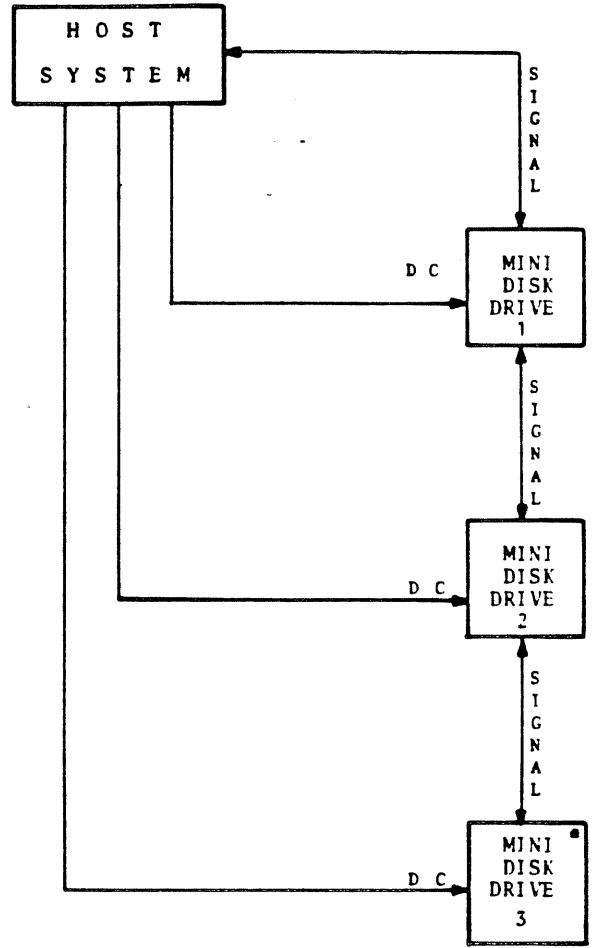

• SIGNAL LINES TERMINATOR

FIGURE 3 - 8 . DAISY CHAIN SELECT CONFIGURATION

3.1.7. SELECTION OF THE DESIRED OPTIONS

3.1.7.1. SELECT OPTIONS

In a single drive configuration the Auto Select Option will be used, in a multi drive configuration the Radial Select Option must be used.

JUMPER		JJ-1			JJ-2	
		1-2	3-4	5-6	5-6	7-8
OPTION						
AUTO SELECT						X
RADIAL SELECT	DRIVE #1	X			X	
	DRIVE #2		X		X	
	DRIVE #5			X	X	

X = Jumper installed

TABLE 3 - 5 . SELECT OPTIONS JUMPERING

3.1.7.2. HEAD LOAD OPTIONS

There are three Head Load Options

- AUTO HEAD LOAD  
HEAD LOAD = INT. SELECT
- SELECTED HEAD LOAD  
HEAD LOAD = INT.SELECT•HEAD LOAD
- RADIAL HEAD LOAD  
HEAD LOAD = HEAD LOAD

JUMPER		JJ-2			JJ-5
		1-2	3-4	9-10	43-44
OPTION					
AUTO HEAD LOAD					X
SELECTED HEAD LOAD		X		X	
RADIAL HEAD LOAD			X	X	

TABLE 3 - 4 . HEAD LOAD OPTION JUMPERING

3.1.7.3. IN USE / DISK CHANGE OPTION

Pin 34 of the interface can be used as IN USE (INPUT) or DISK CHANGE (OUTPUT) (see Table 3 - 5 ).

JUMPER		JJ-2	
		11-12	13-14
OPTION			
IN USE OPTION			X
DISK CHANGE OPTION		X	

TABLE 3 - 5 . IN USE / DISK CHANGE OPTION JUMPERING

3.1.7.4. DOOR LOCK OPTIONS

Locking of the door can be accomplished by the following conditions shown in Table 3 - 6 .

JUMPER		JJ-5				JJ-1	
		1-2	7-8	9-10	11-12	13-14	15-16
OPTION							
DOOR LOCK= IN USE *		X		X		X	
" = I/O ENA			X				
" = HDLOAD ENA					X		
" = IN USE + * IN USE FF		X		X		X	
" = IN USE + * I/O ENA		X		X		X	
" = IN USE + * IN USE FF + I/O ENA		X		X		X	
" = IN USE + * HDLOAD		X		X		X	
" = IN USE + * IN USE FF + HDLOAD		X		X		X	

\* IN USE OPTION must be installed!

TABLE 3 - 6 . DOOR LOCK OPTIONS JUMPERING

3.1.7.5. ACTIVITY LED OPTIONS

The activity LED can be switch on by the following conditions shown in Table 3-7 .

OPTION \ JUMPER	JJ-4	
	5-6	7-8
ACTIVITY LED = HEAD LOAD ENA • SPEED		X
ACTIVITY LED = DOOR LOCK • SPEED	X	

TABLE 3 - 7 . ACTIVITY LED- OPTION JUMPERING

3.1.7.7. STEPPER MOTOR SWITCHING

If the stepper motor shall be enabled by the MOTOR ON signal the following jumper must be installed (see Table 3-9 ).

OPTION \ JUMPER	JJ-4
	1-2
STEP MOTOR = MOTOR ON ENABLL	X

TABLE 3 - 9 . STEPPER MOTOR SWITCHING OPTION JUMPERING

3.1.7.6. WRITE PROTECT OPTION

The fashion how the mini disk is write protected can be selected by jumpers as shown in Table 3-8.

OPTION \ JUMPER	JJ-5		JJ-4
	3-4	5-6	3-4
WRITE PROTECT = NOTCH COVERED		X	X
WRITE PROTECT = NOTCH OPEN	X		

TABLE 3 - 8 . WRITE PROTECT OPTION JUMPERING

5.1.7.8. JUMPER MATRIX

Table 5-10 provides a Jumper Matrix for all Options. For selecting the desired jumpers provide the following:

- Select one of the SELECT options and install the jumpers
- Select one of the Head Load options and install the jumpers
- Select In Use or Disk Change Option.
- Select one of the Door Latch options, if door locking or activity LED is used. Install the jumpers.
- Select one of the Activity LED options and install the jumpers.
- Select one of the Write Protect options and install the jumpers.
- Install the Stepper Motor Switching Jumper if desired.

OPTION		JUMPER	JJ-1			JJ-2				JJ-3				JJ-4				
			1-2	3-4	5-6	1-2	3-4	5-6	7-8	9-10	11-12	13-14	1-2	3-4	5-6	7-8	9-10	11-12
SELECT OPTIONS	ACT. SELECT	DRIVE # 1																
	NATIVE SELECT	DRIVE # 2	X															
		DRIVE # 3		X														
HEAD LOAD OPTIONS	NO HEAD LOAD																	
	SELECTED HEAD LOAD																	
	FAST HEAD LOAD																	
In Use Option	DISK CHANGE OPTION																	
	IN USE OPTION																	
DOOR LOCK OPTIONS	ACT. LOCK = IN USE																	
	" = I/O ENA																	
	" = HDLOAD ENA																	
	" = IN USE + IN USE- FF																	
	" = IN USE + I/O ENA																	
	" = IN USE + IN USE- FF + I/O ENA																	
	" = IN USE + HDLOAD																	
ACTIVITY LED OPTIONS	ACT. LED = HDLOAD ENA + SPEED																	
	" = I/O ENA + SPEED																	
WRITE PROT. OPTIONS	WRITE PROT. = NOTCH COVERED																	
	WRITE PROT. = NOTCH OPEN																	
STEPP. MOTOR	STEPP. MOTOR ENA = MOTOR ON																	

TABLE 5 - 10. OPTION JUMPER MATRIX.

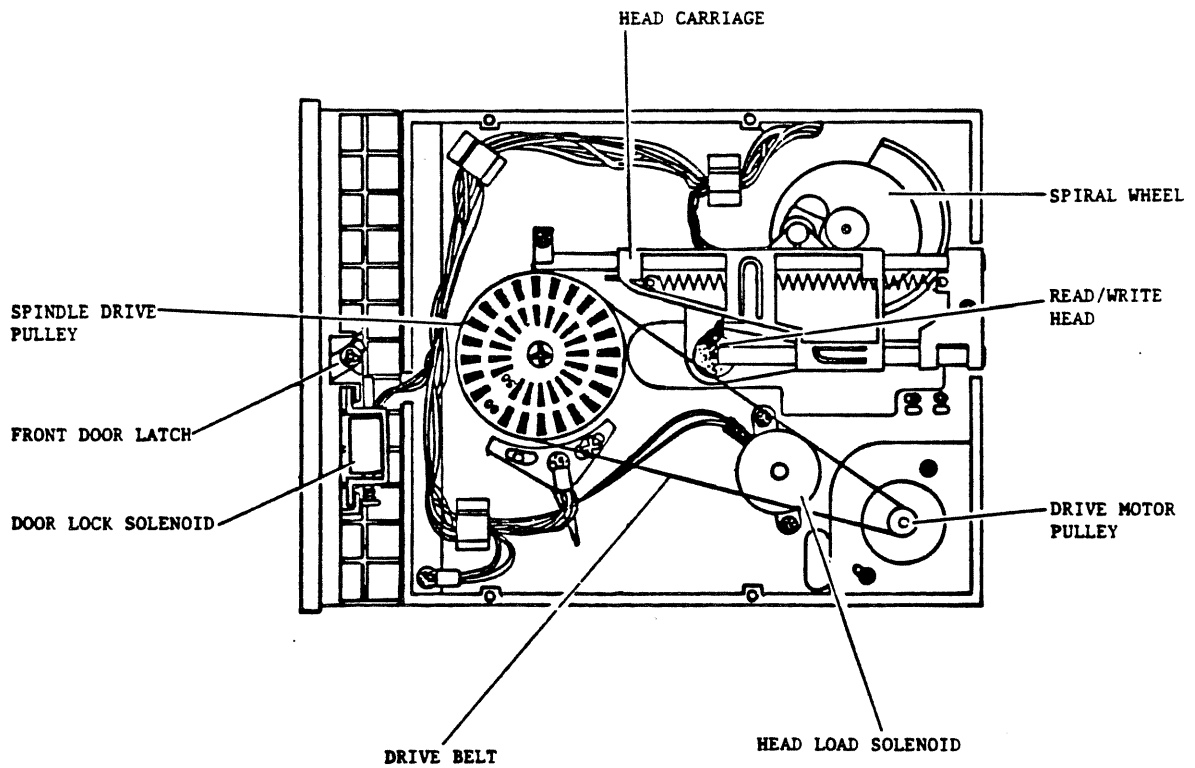
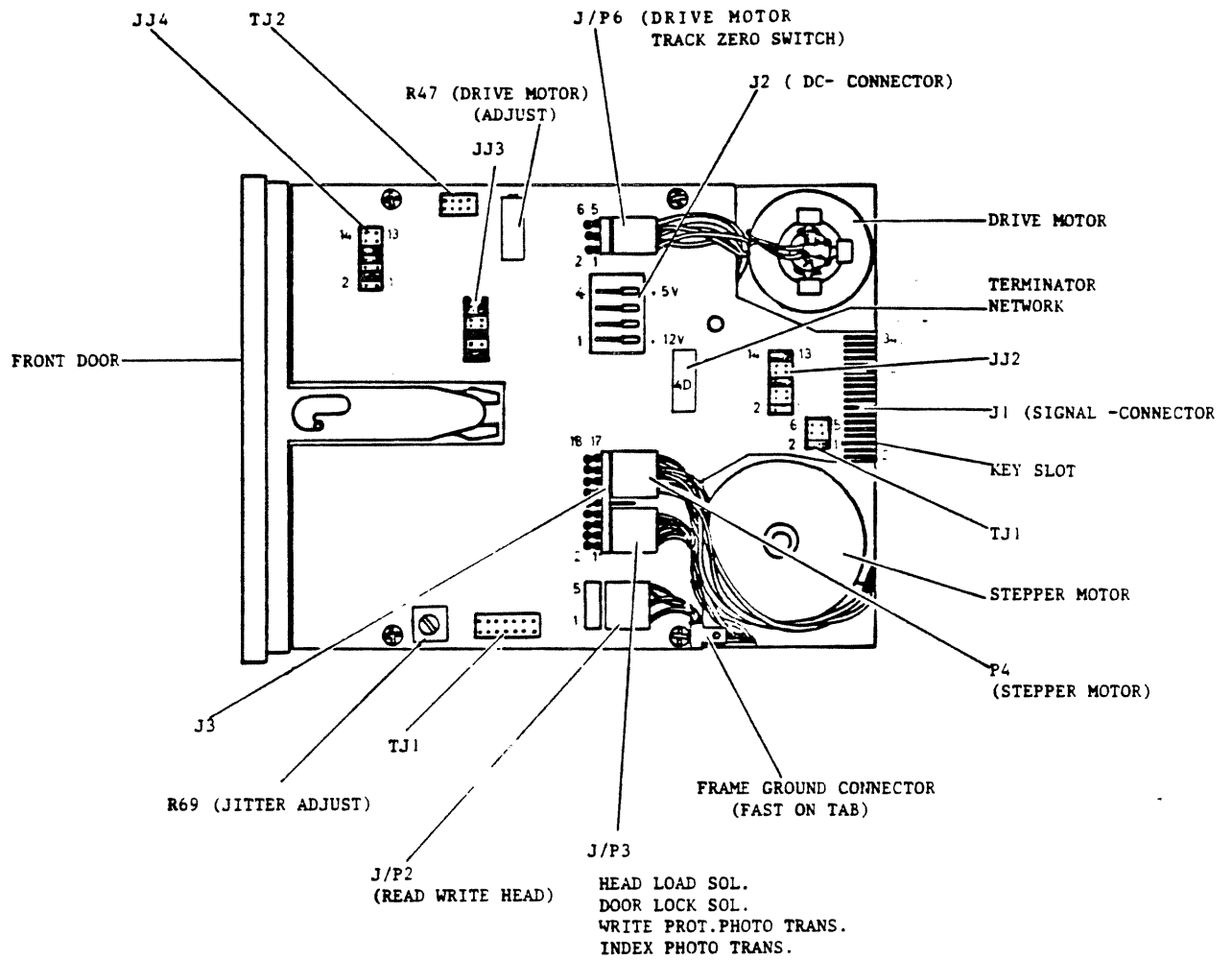

FIGURE 3 - 9 . PART LOCATIONS (PRINZIPAL)

### 3.1.8. DRIVE MOUNTING

#### 3.1.8.1. MOUNTING POSITIONS

The mini disk drive may be mounted in any position.

#### 3.1.8.2. MOUNTING DIMENSIONS

Figure 3-10 shows the outline and mounting dimensions of the mini disk drive. For more detailed information see Specification of the 6106 mini disk drive.

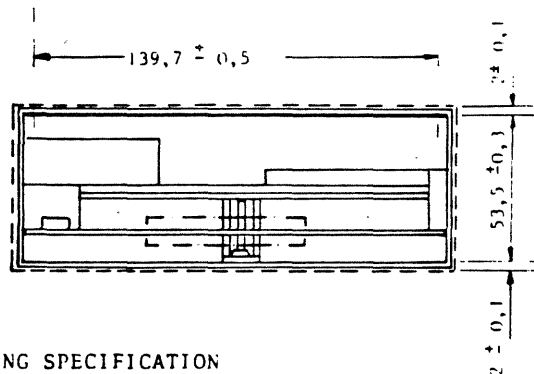
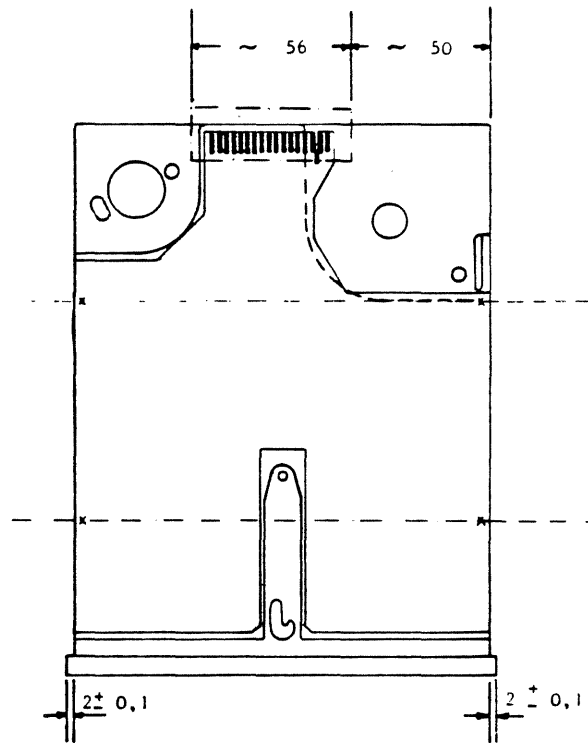
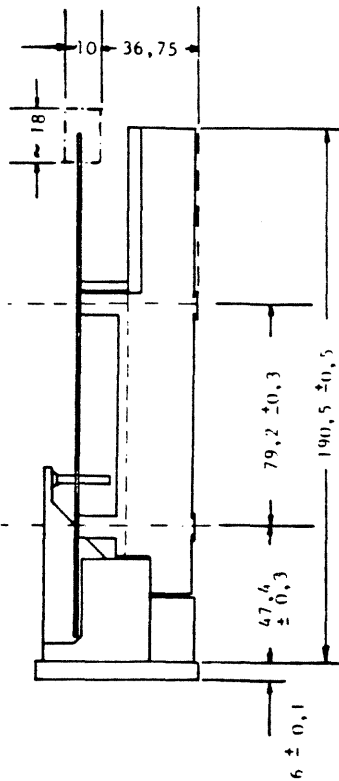
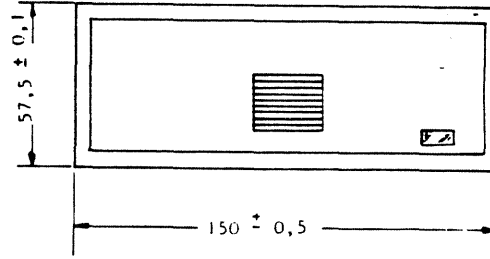

FIGURE 3 - 10. MOUNTING SPECIFICATION



### 3.2. OPERATION

#### 3.2.1. GENERAL

There are no front panel controls on the BASF 6106. All power and control functions are handled through the interface. Operating procedures consist primarily of loading and unloading the mini disk.

#### 3.2.2. MINI DISK STORAGE AND HANDLING

The following are essential requirements for mini disk storage and handling:

- The mini disk should be stored in an environment that is clean and free from all magnetic influences.
- The mini disk should be in same temperature and humidity environment as the disk drive for a minimum of five minutes prior to use.
- Return mini disk to protective envelope when not in use.
- Never place heavy objects on the mini disk cartridge.
- Never touch the mini disk through the cartridge opening when handling.
- Never attempt to clean the mini disk.
- Do not bend or fold the mini disk.
- Do not use rubber bands or paper clips on the mini disk.
- Never write on cartridge (use labels).
- Do not expose mini disk to excessive heat or sunlight.

Proper loading of the mini disk is vital to the operation of the mini disk and drive. Figure 3-11 shows the proper loading of the mini disk.

Procedures for loading and unloading the mini disk drive are given in Tables 3-11 and 3-12 respectively.

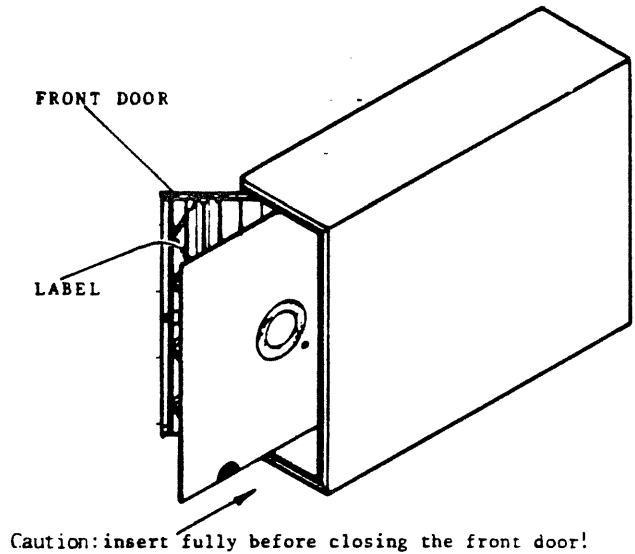

FIGURE 3 - 11. MINI DISK LOADING

STEP	ACTION
1	Press front door to open position
2	Insert minidisk fully with label towards front door
3	Close front door

TABLE 3 - 11 . MINI DISK LOADING

STEP	ACTION
1	Press front door to open position
2	Remove mini disk

TABLE 3 - 12 . MINI DISK UNLOADING

3.2.5. WRITE PROTECT

There are two fashions usual to protect a mini disk from writing:

- a) Write Protect if Notch open (ECMA)
- b) Write Protect if Notch covered (Shugart)

3.2.5.1. WRITE PROTECT IF NOTCH OPEN (ECMA)

Jumper: JJ3 : 3 - 4

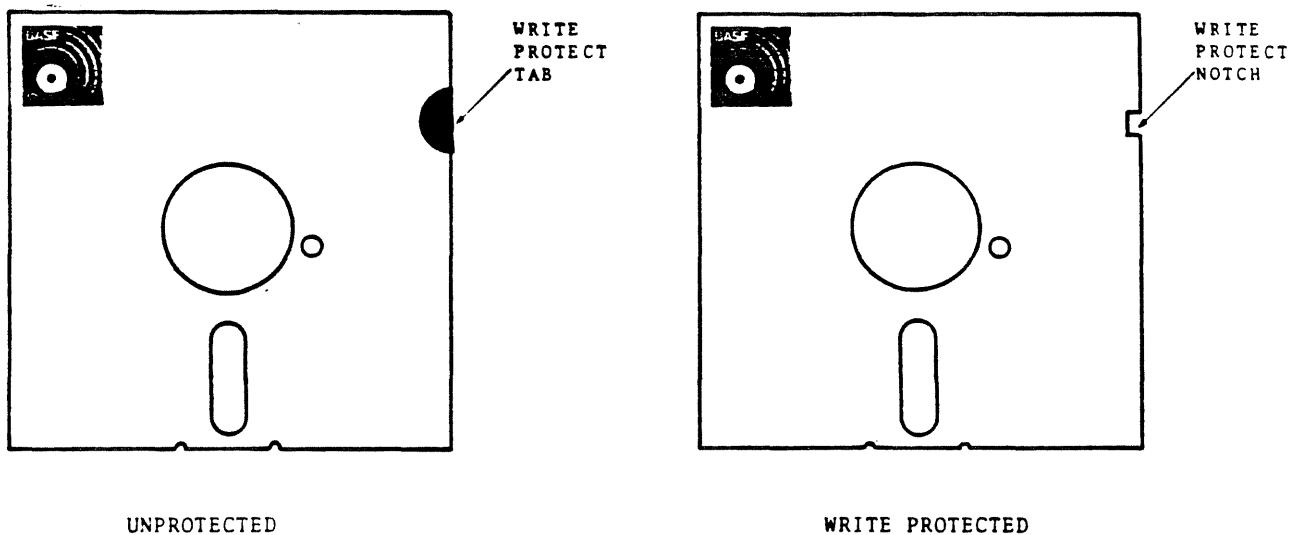

FIGURE 3 - 12 . WRITE PROTECT FEATURE (ECMA)

3.2.5.2. WRITE PROTECT IF NOTCH COVERED (SHUGART)

Jumper : JJ3 : 5 - 6  
JJ4 : 3 - 4

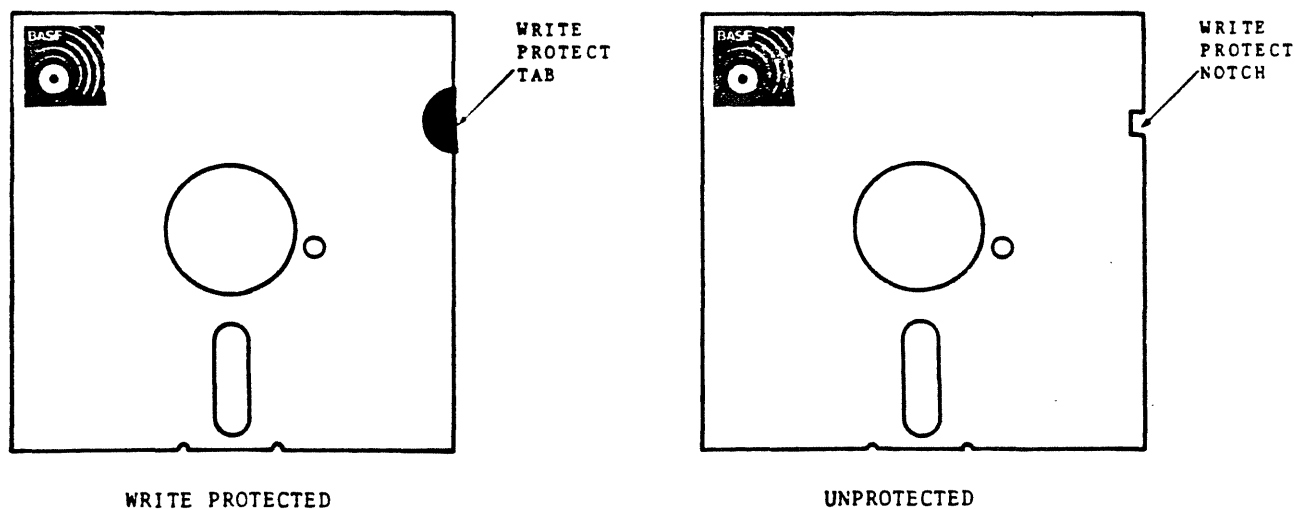

FIGURE 3 - 13 . WRITE PROTECT FEATURE (SHUGART)

# SECTION 4

## MAINTENANCE

### 4.1. GENERAL

This section contains the procedures to performing preventive maintenance, operational checks, alignments and adjustments for the model 6106 mini disk drive.

The BASF 2007 exerciser is a portable unit to operate the mini disk drive off-line. The BASF 2007 will enable the user to make all adjustments and check outs required on the BASF 6106 mini disk drive. The exerciser is provided with controls and indicators to execute all control operations and simulate read and write operations.

### 4.2. TOOLS AND TEST EQUIPMENT

To perform proper maintenance of the mini disk drive, certain tools, test equipment and supplies are required. A list of standard tools and test equipment is provided in table 4-1. Special tools and test equipment are listed in table 4-2.

Common hand tools
Freon
Cotton tipped swabs (Q-tips)
Soft lint-free cloth (gauze)
Voltohmmer
Oscilloscope
Inspection Mirror
Frequency Counter
Dial Gauge (Belt Tension)

TABLE 4 - 1 . STANDARD TOOLS AND TEST EQUIPMENT

BASF - CE - Mini Disk
BASF - CLEANING Mini Disk
Exerciser BASF 2007

TABLE 4 - 2 . SPECIAL TOOLS AND TEST EQUIPMENT

### 4.3. CHECKS, ADJUSTMENTS AND REPLACEMENTS

#### 4.3.1. PCB REPLACEMENT

- a. Turn off DC voltages.
- b. Remove P1, P2, P3, P4, P5, P6.
- c. Remove the 4 mounting screws.
- d. To reinstall, reverse the above.
- e. Check and readjust the INDEX-detector.
- f. Readjust the drive motor speed and jitter, if a new PCB was installed.

#### 4.3.2. SPINDLE DRIVE SYSTEM

The spindle drive system consists of the drive motor, the drive motor pulley, the spindle drive belt and the spindle drive pulley.

##### 4.3.3.1. DRIVE MOTOR AND DRIVE-BELT CHECKS

- a. Turn off the DC input power
- b. Rotate drive motor manually and inspect- drive belt for wear , cracks or fraying edges.  
Replace drive belt, if necessary.
- c. Rotate motor manually and inspect for bearing noises or binding. Replace drive motor, if necessary.  
(Ref. to Drive Motor Replacement Procedure)
- d. Turn on DC power to mini disk drive
- e. Start drive motor (MOTOR ON/ active)
- f. Verify that drive motor and drive belt operates normally and that drive belt tracks evenly and smoothly in center of both pulleys.

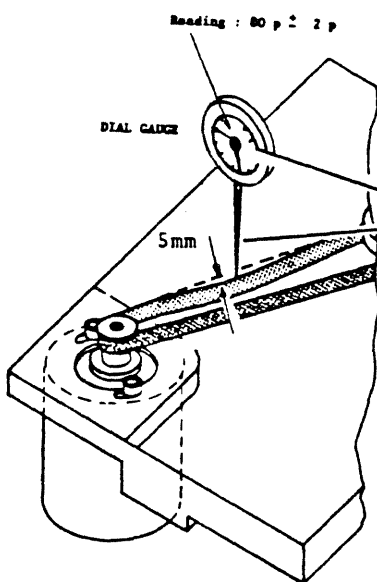

##### 4.3.2.2. DRIVE BELT TENSION CHECK

- a. Take a dial gauge and press it against the drive belt until the deflection of the belt is 5 mm.
- b. The reading on the gauge must be ~ 80 p
- c. If the measured value is out of limits perform drive belt tension adjustment.

Reading 80 p  $\pm$  2 p

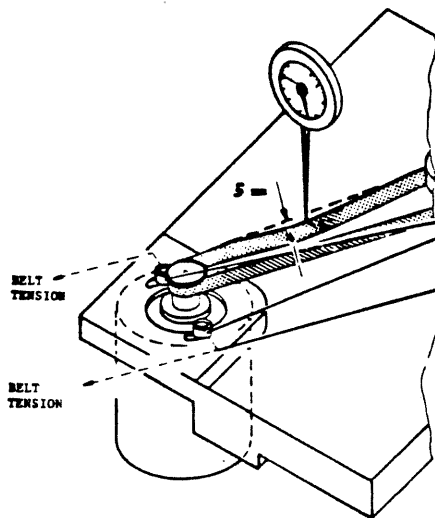

#### 4.3.2.3. DRIVE BELT TENSION ADJUSTMENT

- a. Slightly loose the drive motor set-screws.
- b. Adjust the drive belt tension for a Reading of 80 p on the dial gauge , when the drive belt is 5 mm deflected.
- c. Tighten the drive motor setscrews.

#### 4.3.2.4. DRIVE MOTOR SPEED CHECK

- a. Load a BASF CE Mini Disk or a torque reference disk.
- b. Turn on drive motor
- c. Allow 5 minutes warm up time.

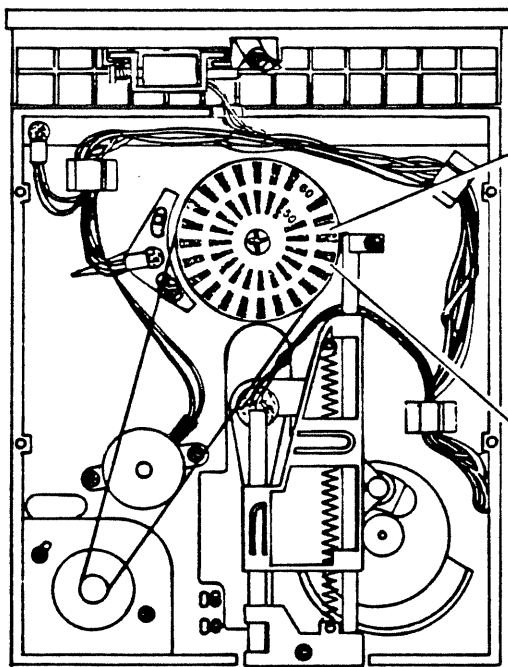

- d. Check that the dark lines of the tacho disk on the spindle pulley appear motionless. Use the inside ring for 50 Hz and the outside ring for 60 Hz.\*

#### 4.3.2.5. DRIVE MOTOR SPEED ADJUSTMENT

- a. Load a BASF CE Mini Disk or a torque reference disk.
- b. Turn on drive motor.
- c. Allow 5 minutes warm up time.
- d. Turn the potentiometer R 47 until the dark lines of the tacho disk on the spindle pulley appear motionless. Use the inside ring for 50 Hz and the outside ring for 60 Hz.\*

\* This adjustment is only possible in an area where fluorescent light exists. Otherwise provide the adjustment or check as shown in 4.3.2.6.

4.3.2.6. DRIVE MOTOR SPEED ADJUSTMENT  
USING A FREQUENCY COUNTER

- a. Load a BASF CE- Mini Disk or a torque reference disk.
- b. Connect a frequency counter to TJ2-8 (INDEX)
- c. Turn on the drive motor.
- d. Allow 5 minutes warm up time.
- e. Measure time between two consecutive INDEX- pulses and adjust poti R 47 to 200 msec  $\pm$  1 msec if necessary.

4.3.2.7. DRIVE MOTOR REPLACEMENT

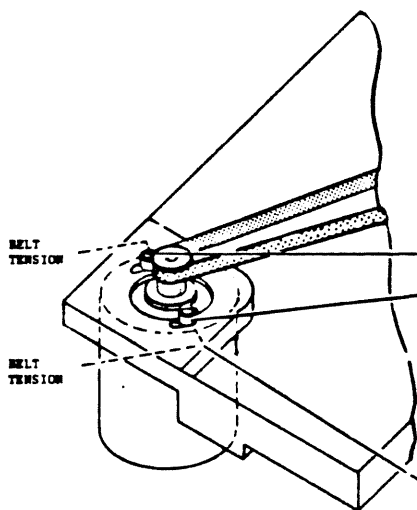

- a. Remove mini disk drive from mounting, and place it on a clean work surface.
- b. Remove drive belt.
- c. Remove wire 2 and 4 of P6.
- d. Remove the two drive motor set screws. Drive motor is now loosened from disk drive.
- e. Place new drive motor in same position and fasten it slightly. Tighten drive motor setscrews.
- f. Re install wire 2 and 6 P6.
- g. Install drive belt and verify correct tracking.
- h. Provide drive belt tension adjustment procedure (4.4.2.3).

#### 4.3.3. POSITIONING SYSTEM

The positioning system consists of the stepper motor with spiral wheel, the head carriage assembly and the track 00 microswitch.

##### 4.3.3.1. TRACK ADJUSTMENT CHECK

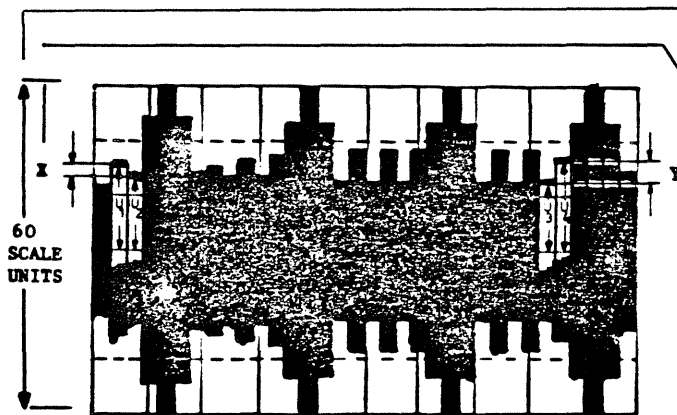
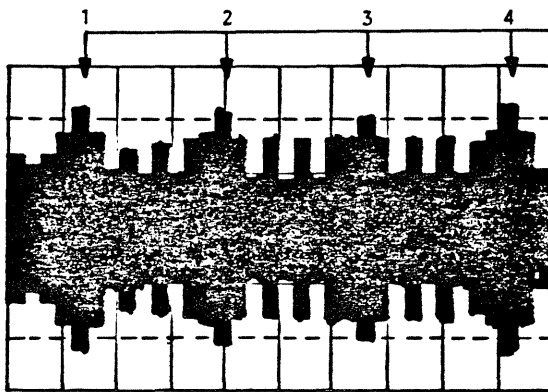

- a. Load a BASF - CE Mini Disk
- b. Start the drive motor and select the mini disk drive.
- c. Allow 10 minutes warm up time, then step the carriage to track 16.
- d. Measure with oscilloscope:
  - SYNC : EXT. POS. TJ2-8 INDEX
  - CH 1 : AC 50 mV uncalibrated inverted TJ1-7
  - CH 2 : AC 50 mV uncalibrated TJ1-9
  - MODE : ADD
  - TIME
  - BASE : 10 ms/ Div. uncalibrated

e. Monitor the read signal on the screen and adjust the time base of the scope until four orientation bursts are shown.

f. Turn the variable gain potentiometer until the amplitude of the first orientation burst reaches 60 scale units.

g. Determine X and Y. (see Example!)

$$X = U_1 - U_2 \quad \text{Caution: Pay attention to sign}$$

$$Y = U_3 - U_4$$

h. Calculate Z

$$Z = X + Y$$

i. If Z exceeds 15 scale units proceed with point e. of track adjustment procedure (4.4.3.2.).

##### EXAMPLE:

$$X = U_1 - U_2 = + 2 \text{ scale units}$$

$$Y = U_3 - U_4 = - 4 \text{ scale units}$$

$$Z = X + Y = + 2 - 4 = - 2 \text{ scale units}$$

#### 4.3.3.2. TRACK ADJUSTMENT

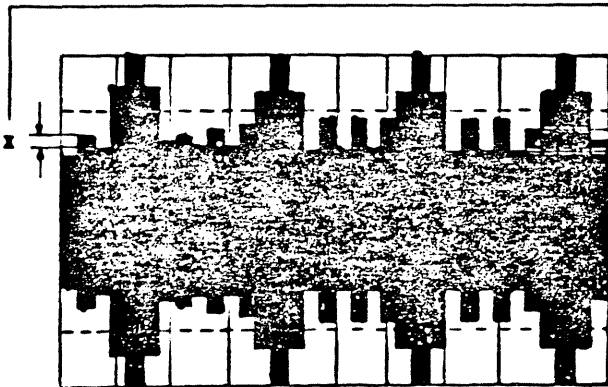
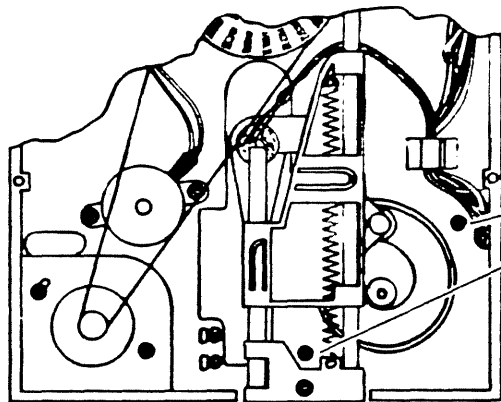
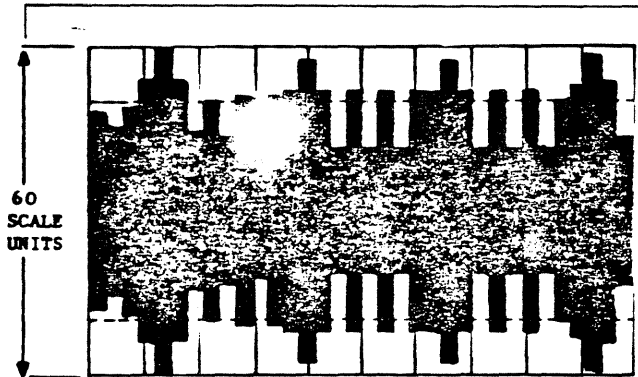
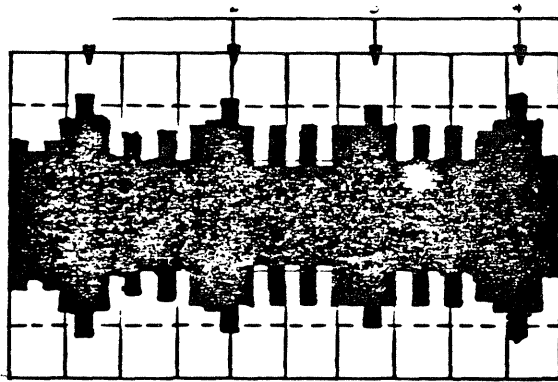

- a. Load a BASF CE Mini Disk
- b. Start the drive motor and select the mini disk drive.
- c. Allow 10 minutes warm up time then step the carriage to track 16.
- d. Measure with oscilloscope

SYNC : EXT. POS.      TJC-8      INDEX

CH 1 : AC 50 mV uncalibrated inverted TJI-7

CH 2 : AC 50 mV uncalibrated      TJI-9

MODE : ADD

Time

Base : 10 msec/Div. uncalibrated

- e. Loosen the mounting screws of the stepper motor and rotate body of the stepper motor until the maximum amplitude of the orientation bursts is reached.
- f. Monitor the read signal on the screen and adjust the time base of the scope until four orientation bursts are shown.
- g. Turn the variable gain potentiometer until the amplitudes of the first orientation burst reaches 60 scale units.
- h. Loosen the stepper motor screws.
- i. Rotate the body of the stepper motor until the X and Y has the same value but opposite sign, or both are zero.
- k. Tighten the mounting screws of the stepper motor.
- l. Recheck the adjustment. If  $X + Y$  exceeds 3 scale units readjust the stepper motor (Pay attention to sign!).
- m. Perform track zero switch adjustment check (4.4.3.3.).



#### 4.3.3.3. TRACK ZERO SWITCH ADJUSTMENT CHECK

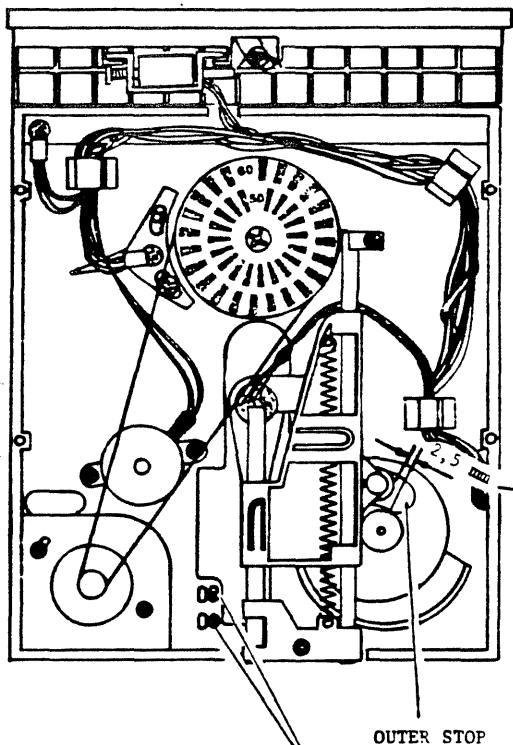

- a. Select mini disk drive and start drive motor.
- b. Monitor TJ2-3 (TRACK ZERO SWITCH)

SYNC : AUTO  
 CH 1 : 2 V / Div. TJ2-3  
 MODE : CH 1 only  
 TIME  
 BASE : 10 msec / Div.

- c. Step out to track 0
- d. Check space between head carriage and outer stop for ~ 2.5 mm. If the space is not correct provide track zero switch adjustment.
- e. Check if track zero switch closes (TJ2-3 → low) between track 3 and 2 when stepping towards track zero and opens (TJ2-3 → high) between track 2 and 3 when stepping from track 0 to track 4. If the track zero switch will not change within these limits provide track zero switch adjustment.

#### 4.5.3.4. TRACK ZERO SWITCH ADJUSTMENT

- a. Load Test Disk
- b. Select mini disk drive and start drive motor.
- c. Measure with Oscilloscope.

SYNC : AUTO  
 CH 1 : 2V/DIV TJ2-6  
 (TRACK 00)  
 CH 2 : 2V/DIV TJ2-3  
 (TRACK 0 - SWITCH )  
 MODE : Chopped

TIME  
 BASE : 10 msec/DIV

- d. Step the head carriage out until the head carriage touches the outer stop.
- e. Step in until CH1 goes high (normally one step in). Now the head carriage is positioned at track 0.
- f. Loosen the track 0 switch and adjust it that it will close (TJ2-3: high → low) between track 3 and 2 when the head carriage is moved towards track 0 and will open (TJ2-3: low → high) between track 2 and 3 when the head carriage is stepped from track 0 to track 4.

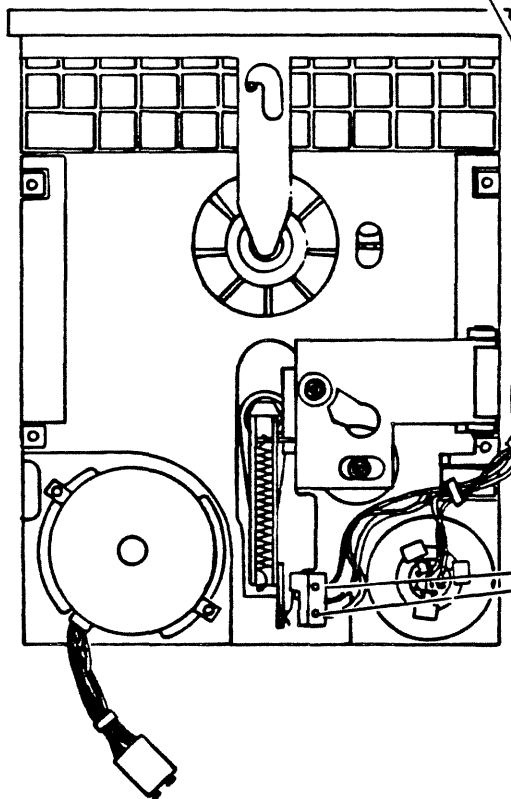

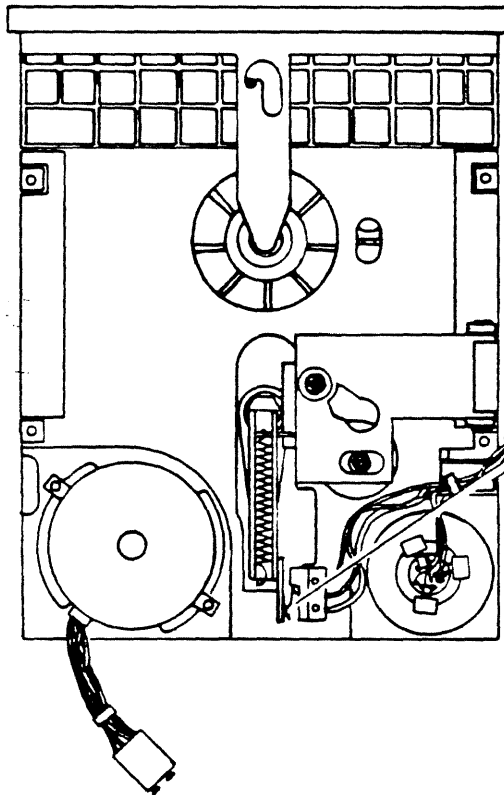

#### 4.3.3.5. TRACK ZERO SWITCH REPLACEMENT

- a. Turn off all DC input power.
- b. Remove PCB.
- c. Remove holding screws of the track zero switch (on the rear).
- d. Remove the wires of the track zero switch.
- e. Connect the wires to the new track zero switch.
- f. Install the new track zero switch and the PCB.
- g. Provide the track zero switch adjustment.

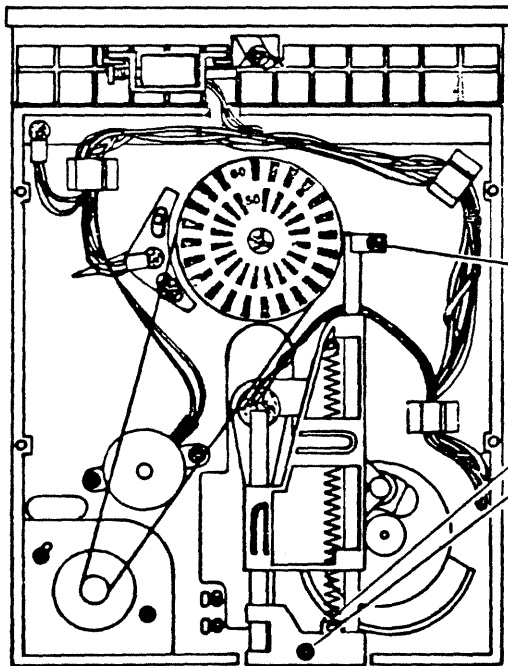

#### 4.3.3.6. HEAD CARRIAGE REPLACEMENT

- a. Remove mini disk drive from mounting and place it on a clean working surface.
  - b. Disconnect P2.
  - c. Disengage the spring.
  - d. Loosen the two holding screws and take carefully out the carriage with the guide bars.
  - e. Pull out the guide bars from the R/W head carriage.
  - f. To reinstall the new head carriage reverse the above procedure.
- Caution: Handle spring carefully during reinstalling
- g. Provide the track adjustment accordingly (4.4.3.2).
  - h. Check the track zero switch adjustment (4.4.3.3.).

#### 4.3.3.7. STEPPER MOTOR REPLACEMENT

(Only applicable with Alu- Spiral-Cam).

- a. Remove mini disk drive from mounting and place it on a clean working surface.
- b. Disconnect P4
- c. Loosen the spiral wheel setscrew.
- d. Loosen the stepper motor holding screws and remove the stepper motor.
- e. To reinstall the new stepper motor reverse the above procedure.
- f. Monitor TRACK 0

SYNC : AUTO  
CH 1 : 2V/DIV TJ2-6  
MODE : CH 1 ONLY  
TIME BASE: 10 msec / DIV

- g. Step out to track 0.
- h. Step to track 36
- i. Provide the track adjustment accordingly (4.4.3.2.).

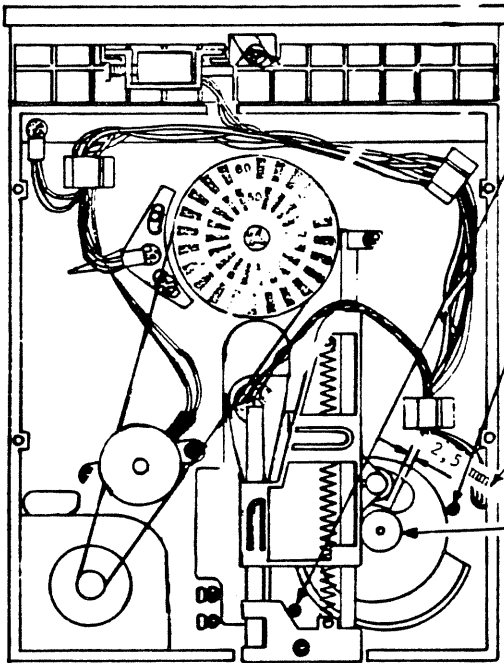
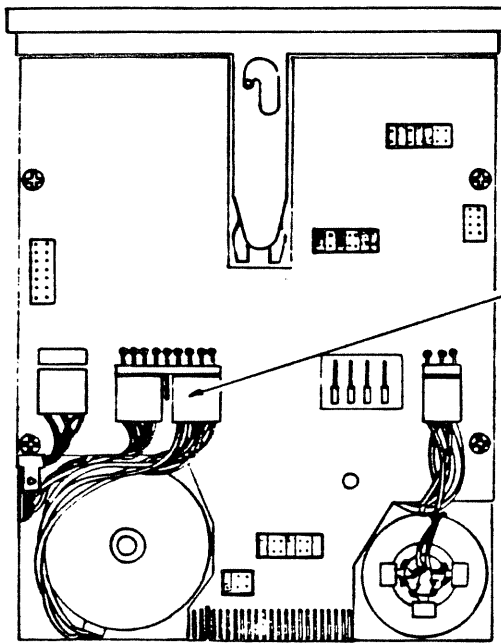

#### 4.3.3.8. SPIRAL WHEEL REPLACEMENT

(Only applicable with Alu-Spiral-Cam).

- a. Remove the stepper motor (see 4.4.3.7.).
- b. Remove the spiral wheel.
- c. Reinstall the stepper motor and the new spiral wheel.
- d. Continue with point f. of the stepper motor replacement procedure (4.4.3.7.).

#### 4.3.4. HEAD LOAD MECHANISM

##### 4.3.4.1. HEAD LOAD ACTUATOR CHECK

- a. Load the head
- b. The clearance between the head load actuator and the pin on the head load pressure arm should be 0,5 mm.
- c. If there is no space between the head load actuator and the pin on the head load pressure arm, perform head load adjustment (4.4.4.2.).

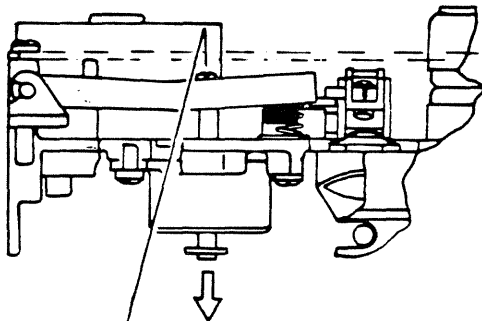

SETScrew

##### 4.3.4.2. HEAD LOAD ACTUATOR ADJUSTMENT

- a. Remove the mini disk drive from mounting and place it on a clean working surface.
- b. Remove the PCB(see 4.4.1.1.).
- c. Manually load the head by pulling the head load solenoid and adjust the setcrew for a clearance of 0,5 mm between head load actuator and the pin on the head load pressure arm.
- d. Release the head load solenoid and check the clearance between the head load pad and the read / write head for 4 ÷ 5 mm.
- e. Reinstall the PCB and the mini disk drive.

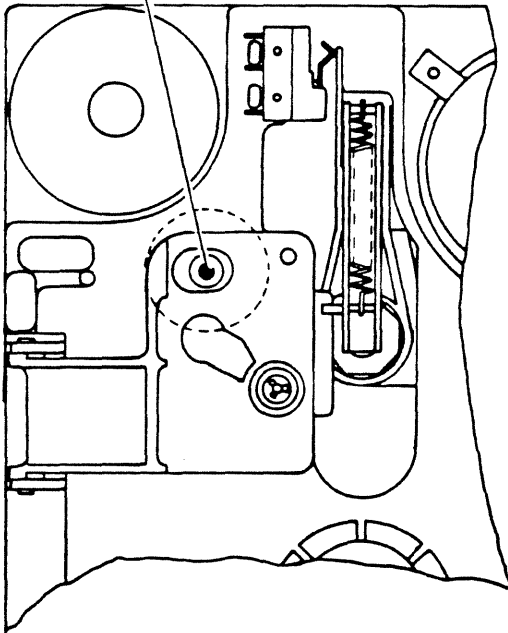

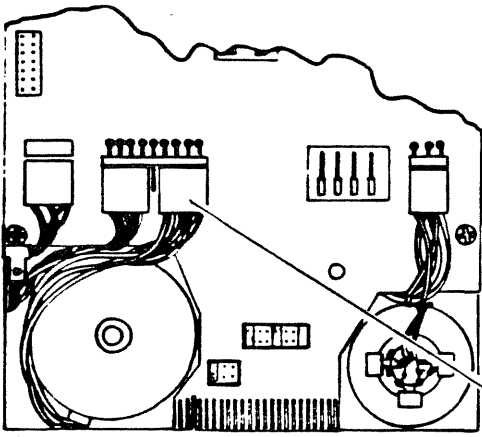

#### 4.3.4.3. HEAD LOAD SOLENOID REPLACEMENT

- a. Remove mini disk drive from mounting and place it on a clean working surface.
- b. Extract wire 1 and 3 from connector P3.

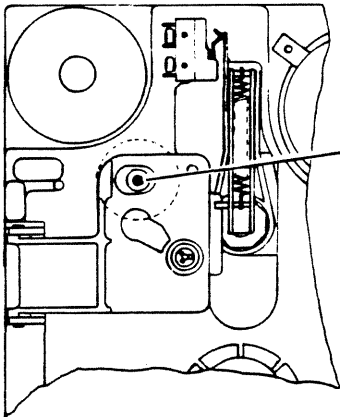

- c. Remove the screw on the head load actuator.

- d. Loosen the two holding screws and remove the head load solenoid.

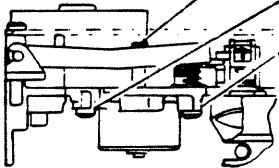

- e. To reinstall the head load solenoid reverse the above.

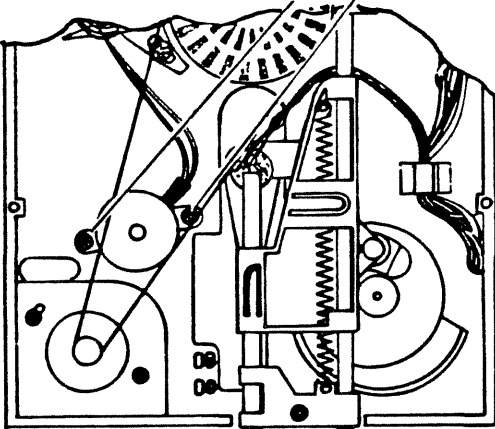

#### 4.3.5. READ/WRITE ELECTRONICS

##### 4.3.5.1 JITTER CHECK AND ADJUSTMENT

- a. Load a BASF Mini Disk
- b. Turn on drive motor
- c. Step to track 39
- d. Write all " ones "
- e. Measure with oscilloscope

SYNC	INT.	POS.	CH1
CH1	AC	200mV/div	TJ1-7
CH2	DC	2V/div	1D-9 READDATA

- f. Trigger Oscilloscope so, that the read data signal as " cateyes " are displayed.
- g. Measure jitter. If necessary adjust poti R 69 for jitter  $\leq$  100 nsec.
- h. Step to track 0
- i. Check for jitter  $\leq$  500 nsec  
If this value is exceeded replace the R/W- Control PCB

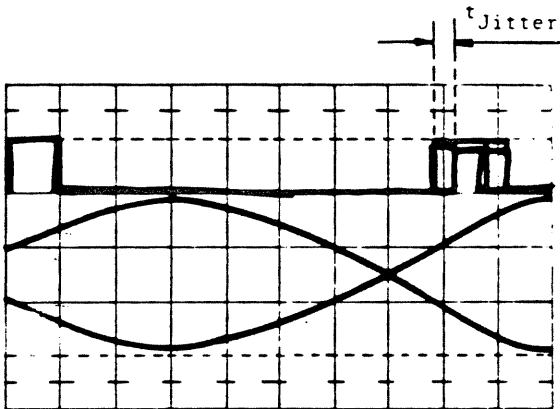

Before Adjustment

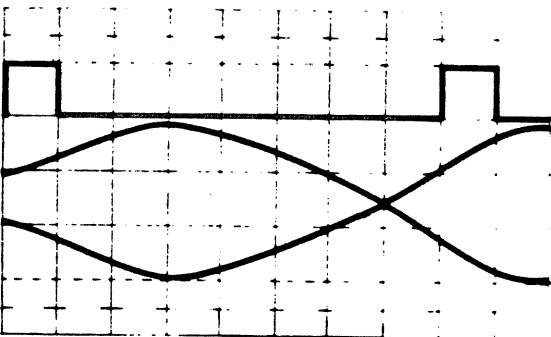

4.3.6.1. PHOTO TRANSISTOR REPLACEMENT

- a. Disconnect plug of defect photo transistor.
- b. Remove photo transistor
- c. Insert new photo transistor
- d. Reconnect plug -
- e. Check the function of the photo transistor
- d. Provide the Index detector adjustment, if the Index photo transistor have been changed.

4.3.6.2 LED - Replacement

- a. Solder out the LED
- b. Put in the new LED
- c. Check the function of the LED
- d. Provide the index detector adjustment if the Index LED have been changed.

4.3.6.3. INDEX DETECTOR ADJUSTMENT CHECK

- a. Load a BASF - CE mini disk
- b. Start the drive motor and select the mini disk drive
- c. Step to track 0
- d. Measure with oscilloscope:  
SYNC : EXT. POS. TJ2-8  
CH1 : AC 100 mV inverted TJ1-7  
CH2 : AC 100 mV TJ1-9  
MODE : ADD  
TIME  
BASE : 100  $\mu$ sec / Div
- e. Check the timing between start of the sweep and the data burst for 450  $\mu$ sec  $\pm$  80  $\mu$ sec
- f. Provide the index detector adjustment (4.4.6.4.) if necessary.

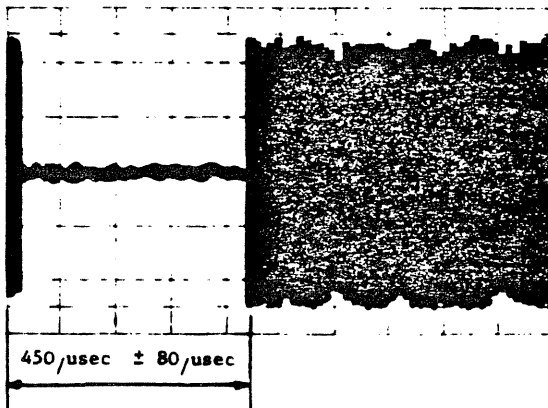

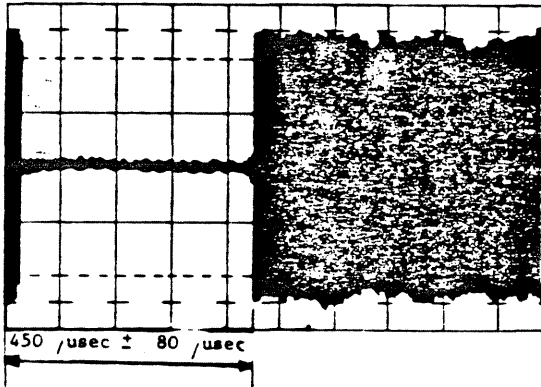

#### 4.3.6.4. INDEX DETECTOR ADJUSTMENT

- a. Load a BASF - CE Mini Disk
- b. Start the drive motor and select the mini disk drive-
- c. Step to track 0
- d. Messure with oscilloscope:

SYNC : EXT. POS. TJ2-8 INDEX  
 CH 1 : AC 100 mV inverted TJ1-7  
 CH 2 : AC 100 mV TJ1-9  
 MODE : 100  $\mu$ sec /Div.  
 TIME : 100  $\mu$ sec / Div.  
 BASE

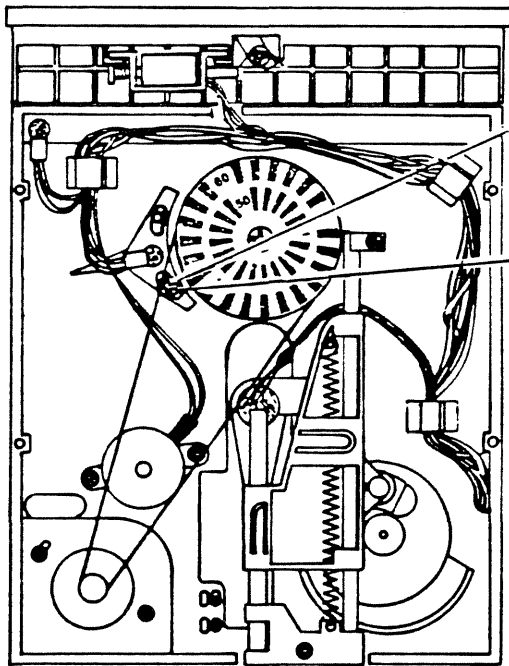

- e. Loosen the set screw of the index - holder
- f. Adjust the time delay between start of the sweep and the data burst to 450  $\mu$ sec  $\pm$  80  $\mu$ sec.
- g. Tighten the index holder set screw.



4.4. LOCATION OF TESTPOINTS, IC's, POTENTIOMETERS AND CONNECTORS

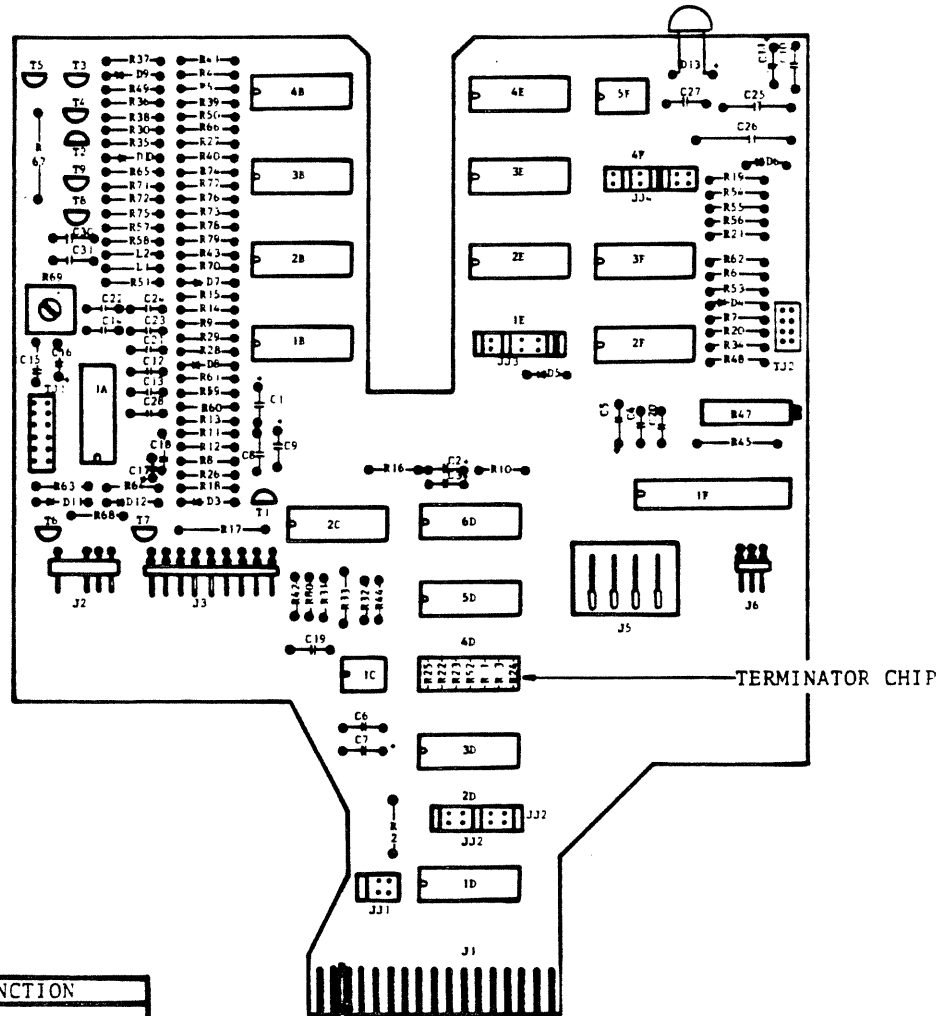

POT1	FUNCTION
R 47	Drive Motor Adjust
R 69	Jitter Adjust

Connector	Function	
J1	Signal - Interface	
J2	Read/Write - Head	
J3	1,3	Head Load Solenoid
	2,4	Door Lock Solenoid
	5,6	Write Protect Phototransistor
	7,8	Index Phototransistor
	11-18	Stepper Motor
J5	DC- Connector	
J6	2,4	Drive Motor
	3,5,6	Track Zero Switch

Test Points	Signal	
TJ1	1,2	Write Current Signal
	3,5	Read Signal (Preamp. Output)
	6	GND
	7,9	Read Signal (Differentiator Input)
	8	Jitter Voltage
	10	Erase Current T.P.
TJ2	11,12	Write Current T.P.
	1	DISK CHANGE FF/
	2	PWRONRESET/
	3	N.O. TRACK ZERO SWITCH
	4	IN USE- FF
	5	MOTOR ON
	6	TRACK OO
	7	GND
8	INDEX	



# SECTION 5

## ILLUSTRATED PARTS BREAKDOWN

### 5.1. GENERAL

This section contains an illustrated parts breakdown, the parts catalogue and the PCB component locations. This section is intended for use in requisitioning, storing, and issuing of replacement parts.

### 5.2. PARTS BREAKDOWN

Fig. 5-1 shows the component parts of the mini disk drive and their physical relationships.

### 5.3. PARTS CATALOGUE

The parts catalogue (Table 5-1) consists of a complete breakdown of the 6106 mini disk drive into assemblies, subassemblies and detailed parts. The item number corresponds to the numbers on the parts breakdown drawing.

### 5.4. PCB COMPONENTS

The locations of the components of the Read/Write Control- PCB are shown on Fig. 5 - 2. Table 5 - 2 lists the components of the Read/Write Control - PCB.

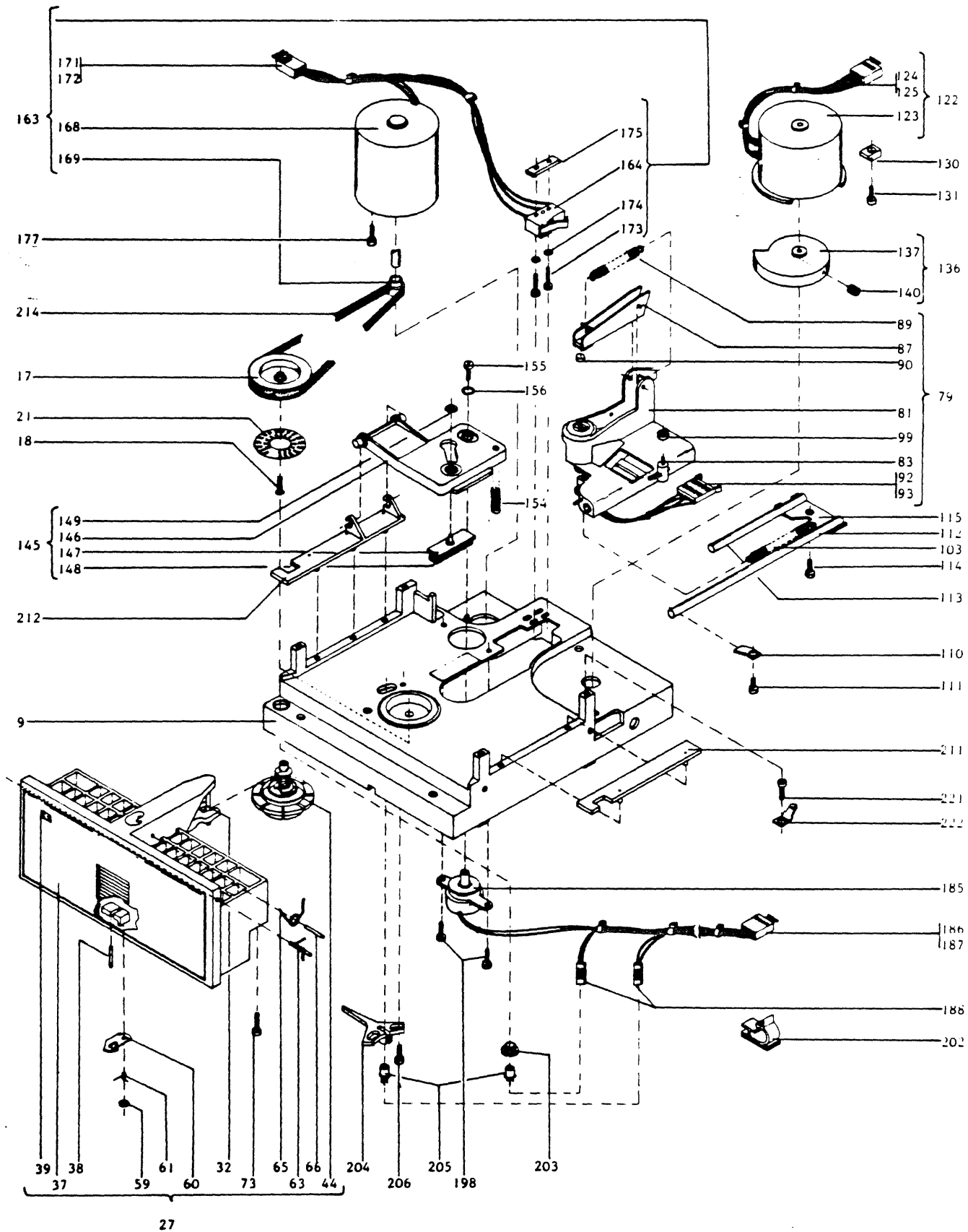

FIGURE 5 - 1 . PARTS BREAKDOWN

ITEM	STRUCTURE					PART NR.		DESCRIPTION	QTY PER ASSY											
	0	1	2	3	4				88 101 - 4XX	01	02									
0000																				
1	0					88 101-4XX	01	FINAL ASSY, MDD 6106												
2						88 417-003	01	NAME PLATE			1	1								
3																				
4																				
5	00					88 100-002		ASSY, MDD BASIS			1	1								
6																				
7																				
8																				
9	01					88 125-001	02	ASSY, DECK SPINDLE			1	1								
0010		1				88 176-001	05	DECK, MACHINED			1	1								
1			2			88 175-001	07	DECK, CASTING			1	1								
2			3			88 181-001	01	SPINDLE, MACHINED			1	1								
3			4			88 180-001	02	SPINDLE, CASTING			1	1								
4			5			88 418-001	01	BEARING, BALL $\varnothing 6 \times \varnothing 19 \times 6$			2	2								
5			6			88 255-001	01	RING, DISTANCE			1	1								
6			7			88 300-196	01	RETAINER, RING BSR 19			1	1								
7			8			88 250-002	04	PULLEY $\varnothing 42$			1	1								
8			9			60 957-007	01	SCREW COUNTERSUNK M 3 x 8 5,8			1	1								
9			10			88 302-007	01	SPRING, PRELOAD BEARING 18,8 x 9,2x0,25			2	2								
0020			11			88 306-061	01	SHIM, SPACER $\varnothing 6 \times \varnothing 12 \times 0,1$			1	1								
1			12			88 421-001	01	LABEL, TACHOSCOPE			1	1								
2			13			700702-005	01	LOCTITE, GREEN												
3																				
4																				
5																				
6																				
7	05					88 126-001	01	ASSY, FRONT CABINETT			1	1								
8	05					88 126-002	01	ASSY, FRONT CABINETT SHUGART			-	-								
9		1				88 200-001	07	FRONT CABINETT			1	1								
0030		1				88 201-001	05	FRONT CABINETT SHUGART			-	-								
1			1			88 254-001	02	INSERT, MOLDING			2	2								
2			2			88 307-001	05	PIN, GUIDE $\varnothing 3 \times 25$			1	1								
3																				
4																				
5																				
6		2				88 131-001	01	ASSY, FRONT DOOR			1	1								
7			1			88 202-001	05	FRONT DOOR			1	1								
8				1		88 311-001	02	PIN $\varnothing 1,5 \times 10$			1	1								
9			2			88 423-001	01	READY WINDOW (RED)			1	1								
0040																				
1			3			700703-001	01	LUBRICATING GREASE												
2																				
3																				
4		4				88 129-002	05	ASSY, CONE THRUST			1	1								
5			1			88 204-002	07	CONE THRUST			1	1								
6			2			88 205-002	05	FOLLOWER CONE			1	1								
7			3			88 301-020	01	SHIVN, SPACER $\varnothing 6 \times \varnothing 8 \times 0,12$			1	1								
8																				
9			5			80 960-608	01	RETAINER, RING 5			1	1								

TABLE 5 - 1 . PARTS CATALOG 6106

ITEM	STRUCTURE				PART NR.		DESCRIPTION	QTY PER ASSY NR.					
	C	1	2	3				4	88 101 - 4XX				
0050			6		88 403-001	02	SPRING, COMPRESSION	1	1				
1			7		88 419-001	01	BEARING, RADIAL $\emptyset 6 \times \emptyset 13 \times 3,5$	1	1				
2			8		88 252-002	03	TUBE, GUIDE	1	1				
3			9		88 404-001	02	SPRING, COMPRESSION $\emptyset 8$	1	1				
4			10		88 303-012	01	SPRING CUP $\emptyset 12 \times \emptyset 6,2 \times 0,5$	2	2				
5			11		88 314-064	01	RETAINER, RING WSR 6	1	1				
6													
7													
8													
9		5			88 316-020	02	BENDING- QUICKLOCK 2	1	1				
0060		6			88 228-001	02	LATCH	1	1				
1					88 412-001	03	SPRING, TORSION	1	1				
2		8			88 305-014	01	PIN, PIVOT $\emptyset 2 \times 15,8$	2	2				
3		9			88 407-001	02	SPRING, TORSION	2	2				
4													
5		11			88 406-002	03	SPRING, TORSION	1	1				
6		12			88 305-029	01	PIN, PIVOT	1	1				
7		13			88 177-002	08	LEVER ARM- CONE THRUST	1	1				
8													
9													
0070													
1													
2													
3		3			80 958-014	01	CROSS, RECESSED, SCREW M 3 x 6 5,8	2	2				
4		4			88 025-032	02	WASHER, FLAT 3,2 ST	2	2				
5		5			200216-001	01	SCREW, LOCK SEAL	NB	NB				
6													
7													
8													
9		10			88 158-001	02	ASSY, CARRIAGE	1	1				
0080													
1		1			88 150-001	02	CARRIAGE WITH HEAD	1	1				
2		1			88 206-001	04	CARRIAGE	1	1				
3			1		88 308-001	02	PIN SPRING $\emptyset 3 \times 12,5$	1	1				
4													
5													
6													
7		2			88 208-001	05	ARM, HEAD LOAD, MACHINED	1	1				
8		3			88 211-001	01	CLIP, DISTANCE	1	1				
9		4			88 400-001	04	SPRING, EXTENSION	1	1				
0090		5			88 413-001	03	PAD, PRESSURE	1	1				
1		6			105036-001	50	HEAD WITH LEADS	1	1				
2		7			80 965-005	02	CONNECTOR P2	1	1				
3		8			320708-001	01	PIN, CONNECTOR	4	4				
4		9			705007-001		ADHESIVE 309	NB	NB				
5		10			200217-001	02	ADHESIVE 85	NB	NB				
6													
7													
8													
9		2			88 029-001	06	ROLL	1	1				

TABLE 5 - 1 . (cont.) PARTS CATALOG 6106

ITEM	STRUCTURE				PART NR.		DESCRIPTION	QTY PER ASSY NR.	
	0	1	2	3				4	88 101 - 4XX
0100			1		88 050-001	04	RING	1	1
1			2		88 414-001	02	BEARING	1	1
2									
3			3		88 036-001	04	SPRING, EXTENSION	1	1
4									
5									
6									
7									
8									
9									
0110	7				88 227-001	04	SPRING, CLAMPING	1	1
1	8				80 958-014	01	CROSS, RECESSED SCREW M 3 x 6 5,8	1	1
2	9				88 408-001	05	BAR, GUIDE Ø 5 x 130	1	1
3	10				88 409-001	05	BAR, GUIDE Ø 5 x 71	1	1
4	11				80 958-014	01	CROSS, RECESSED, SCREW M 3 x 6 5,8	1	1
5	12				88 226-001	06	SPRING, CLAMPING	1	1
6	13				200216-001	01	SCREW, LOCK SEAL	NB	NB
7									
8									
9									
0120									
1									
2	15				88 151-001	01	ASSY, STEPPER MOTOR	1	1
3	1				88 411-001	02	STEPPER MOTOR	1	1
4	2				96 225-Y02	01	PIN, CONNECTOR	8	8
5	3				80 834-204	WB	CONNECTOR 4 POL. P4	1	1
6	4				355038-001	01	TY, WRAP	4	4
7									
8									
9									
0130	15				88 179-001	04	SHOE, CLAMPING	2	2
1	16				80 958-014	01	CROSS, RECESSED, SCREW	2	2
2	17				200216-001	01	SCREW, LOCK SEAL	NB	NB
3									
4									
5									
6	19				88 063-001	01	ASSY, SPIRAL WHEEL	1	1
7	1				88 027-001	06	SPIRAL WHEEL MACHINED	1	1
8	1				88 210-002		SPIRAL/CAM PLASTIC	1	1
9	3				88 064-001	01	STOP <sup>C</sup>	1	1
0140	4				80 952-016	01	SET SCREW HEX. M 2 x 3	1	1
1	5				200217-001	02	ADHESIVE 85	NB	NB
2									
3									
4									
5	20				88 128-001	01	ASSY, HEAD LOAD ACTUATOR	1	1
6	1				88 209-001	05	FLAP, HEAD LOAD	1	1
7	2				88 203-001	02	PRESSURE PLATE	1	1
8	3				420704-001		FOAM PRESSURE PLATE	1	1
9	4				88 316-020	01	BENZING- QUICKLOCK 2	1	1

TABLE 5 - 1 . (cont.) PARTS CATALOG 6106

ITEM	STRUCTURE					PART NR.	DESCRIPTION	QTY	
	0	1	2	3	4			88 101 - 4X1	01 02
015C									
1									
2									
3									
4		20				88 402-001	02	SPRING, COMPRESSION, FLAP	1 1
5		21				80 958-005	01	CROSS, RECESSED SCREW M 2,5 x 8 5,8	1 1
6		22				87 695-527	02	WASHER, FLAT B 2,7	1 1
7		23				700702-003	01	LOCTITE GREEN	NE NE
8		24				200216-001	01	SCREW, LOCK SEAL	NE NE
9									
0160									
1									
2									
3		25				88 153-Y02	02	ASSY, SPINDLE MOTOR WITH TRACK O- SWITCH	1 1
4			1			88 351-001	02	SWITCH, MICRO	1 1
5			2			80 043-926	WD	WIRE INSULATED WHITE	1 1
6			3			80 043-826	WD	WIRE INSULATED GREY	2 2
7			4			96 225-Y02	01	PIN, CONNECTOR	5 5
8			5			88 415-002	04	SPINDLE MOTOR	1 1
9			6			88 251-002	06	PULLEY	1 1
0170			7			700702-003	01	LOCTITE GREEN	NE NE
1			8			96 225-Y02	01	PIN CONNECTOR	2 2
2			9			80 834-203	WB	CONNECTOR 3 POL. P6	1 1
3		26				89 375-158	A	CROSS, RECESSED SCREW M 2 x 12 5,8	2 2
4		27				88 025-022	02	WASHER, FLAT 2,2 ST	2 2
5		28				88 229-001	03	NUT PLATE	1 1
6									
7		30				80 958-014	01	CROSS, RECESSED SCREW M 3 x 6 5,8	2 2
8		31				88 025-032	02	WASHER, FLAT 3,2 ST	2 2
9		32				200216-001	01	SCREW, LOCK SEAL	NE NE
0180									
1									
2		55				88 160-001	01	HARNESS, OUT S1- RELAY	1 -
3		55				88 160-002	01	HARNESS, WITH S1- RLLAY	- 1
4			1			88 154-001	01	ASSY, HEAD LOAD SOLENOID	1 1
5				1		88 422-001	02	HEAD LOAD SOLENOID	1 1
6				2		96 225-Y02	01	PIN, CONNECTOR	2 2
7			2			80 834-204	WB	CONNECTOR P3	1 1
8			3			320709-002	01	CONNECTOR	2 2
9			4			80 043-926	WD	WIRE, INSULATED WHITE	M M
0190			5			80 043-826	WD	WIRE, INSULATED GREY	M M
1			6			355038-001	01	TY, WRAP	5 5
2			7			96 225-Y02	01	PIN, CONNECTOR	4 6
3			8			80 941-001	01	CONNECTOR	4 4
4			9			88 355-001	03	SOFTW. INTERLOCK SOLENOID	- 1
5									
6									
7									
8		37				80 958-014	01	CROSS, RECESSED SCEW M 3 x 6 5,8	2 2
9									

TABLE 5 - 1 . (cont.) PARTS CATALOG 6106



ITEM	STRUCTURE					PART NR.		DESCRIPTION	QTY PER ASSY MF.	
	0	1	2	3	4				88 101 - 4XX	01 02
0200										
1										
2		40				355027-016	01	CLAMP, CABLE	2	2
3		41				88 255-001	01	HOLDER TRANSISTOR WRT	1	1
4		42				88 207-001	C3	HOLDER TRANSISTOR INDEX	1	1
5		43				505000-001	50	PHOTO TRANSISTOR	2	2
6		44				80 958-014	01	CROSS, RECESSED SCREW M 3x6 5,8	1	1
7		45				88 028-032	02	WASHER FLAT 3,2 ST	1	1
8		46				200216-001	01	SCREW, LOCK SEAL	NB	NB
9										
0210										
1		49				88 212-001	03	DISKETTE GUIDE RIGHT	1	1
2		50				88 213-001	06	DISKETTE GUIDE LEFT	1	1
3										
4		52				88 416-002	03	BELT SPINDLE	1	1
5										
6										
7										
8		60				88 356-001	01	PCB, CONTROL	1	1
9										
0220										
1										
2										
3										
4										
5										
6										
7										
8		65				80 967-001	01	ACCESORIES	1	1
9										
0230										
1										
2										
3										
4										
5										
6										
7										
8										
9										
0240										
1										
2										
3										
4										
5										
6										
7										
8										
9										

TABLE 5 - 1 . (cont.) PARTS CATALOG 6106

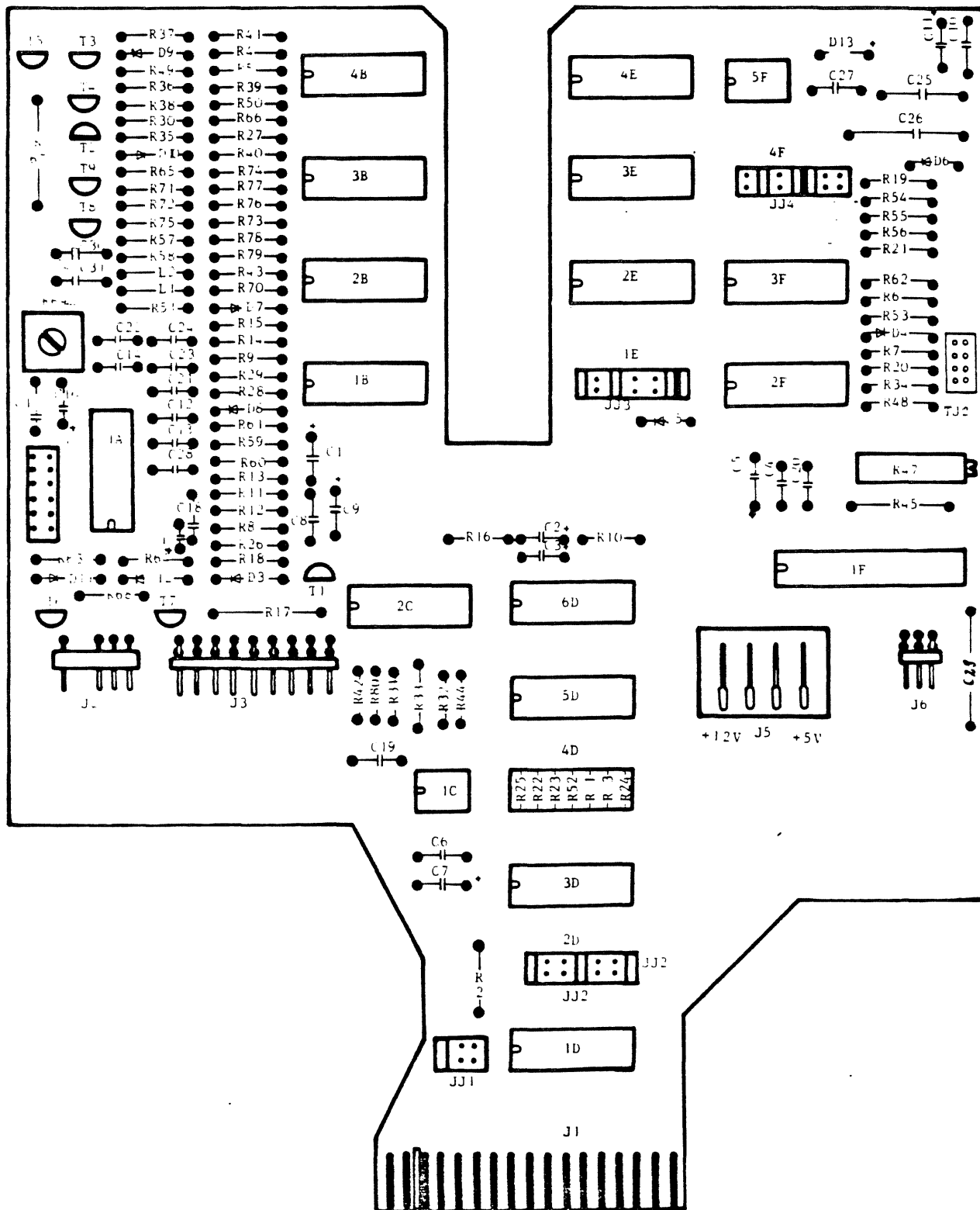

FIGURE 5 - 2 . READ/WRITE CONTROL PCB COMPONENT LOCATIONS

REF. DESIGN.	PART- NR.	DESCRIPTION	QTY PLR ASSY NR.			
			88 356 - XXX	001		
	88 357 - 001	CONTROL, PCB		1		
C 1	80 934 - 053	CAPACITOR TANT. 33 $\mu$ F, 20V, $\pm$ 20%		1		
C 2	80 934 - 041	" " 22 $\mu$ F, 16V, $\pm$ 20%		1		
C 3	80 934 - 076	" " 2,2 $\mu$ F, 35V, $\pm$ 20%		1		
C 4,6,8,10,15,18	305028 - 103	" " 0,01 $\mu$ F, 100V, $\pm$ 20%		6		
C 5	80 934 - 054	" TANT. 47 $\mu$ F, 20V, $\pm$ 20%		1		
C 7,9,11	80 934 - 031	" " 47 $\mu$ F, 10V, $\pm$ 20%		3		
C 12,13	98 175 - 133	" CER. 330 pF, 200V, $\pm$ 10%		2		
C 14	98 175 - 047	" " 47 pF, 200V, $\pm$ 10%		1		
C 16,17	80 934 - 079	" TANT. 6,8 $\mu$ F, 35V, $\pm$ 20%		2		
C 19,20,21,25,50,51	98 175 - 410	" CER. 0,1 $\mu$ F, 50V, $\pm$ 10%		6		
C 22	98 175 - 239	" " 3,9 nF, 100V, $\pm$ 10%		1		
C 24	98 175 - 156	" " 560 pF, 200V, $\pm$ 10%		1		
C 25	88 353 - 153	" POLY. 0,015 $\mu$ F, 200V, $\pm$ 5%		1		
C 26	88 353 - 393	" POLY. 0,039 $\mu$ F, 200V, $\pm$ 5%		1		
C 27	98 175 - 210	" CER. 1 000 pF, 200V, $\pm$ 10%		1		
C 28	10 781 - 422	" " 0,22 $\mu$ F, 50V, $\pm$ 10%		1		
C 29	305028 - 253	" CER. 0,025 $\mu$ F, 100V, $\pm$ 20%		1		
D 3 - D 4	90 344 - 001	DIODE 1N4001		4		
D 5,6	335004 - 001	L.-DIODE MLED 60		2		
D 7	17 202 - 043	DIODE ZENER ZPD 4,3,2 %		1		
D 8	90 346 - 082	DIODE ZENER 1N756 (8,2V)		1		
D 9	90 346 - 068	DIODE ZENER 1N754 (6,8V)		1		
D 10 - D 12	90 342 - 001	DIODE 1N4154		3		
D 13	80 975 - 001	L.- DIODE LD52C		1		
JJ 1	80 836 - 203	CONNECTOR 3P		1		
JJ 2, 3, 4	80 836 - 207	" 7P		3		
J 2	80 946 - 101	CONNECTOR 4P		1		
J 3	80 833 - 209	" 9P		1		
J 5	88 359 - 001	" 4P		1		
J 6	80 833 - 203	" 3P		1		
L 1, 2	80 964 - 390	INDUCTOR IM2 - 390 $\mu$ H , 10%		2		
R 1,3,22,23,24,25,52	10 412 - 115	RESISTOR, NETWORK 150 $\Omega$ , 1/4W, 2%		1		
R 2,19	90 364 - 151	RESISTOR 150 $\Omega$ , 1/4W, 5%		2		
R 4,31,32,59,60,63,64,34	90 364 - 103	" 10 K, 1/4W, 5%		8		
R 5	90 364 - 153	" 15 K, 1/4W, 5%		1		
R 6,7,29,30,36,39,40,50 57,58,62,71,72,	90 364 - 102	" 1 K, 1/4W, 5%		13		
R 8,9,53	90 364 - 332	" 3,3 K, 1/4W, 5%		3		
R 10,26,16	90 364 - 473	" 47 K, 1/4W, 5%		3		
R 11,13,	90 364 - 223	" 22 K, 1/4W, 5%		2		
R 12,80	90 364 - 104	" 100 K, 1/4W, 5%		2		
R 14,15	90 364 - 823	" 82 K, 1/4W, 5%		2		
R 17	90 366 - 409	" 82 $\Omega$ , 1/4W, 5%		1		
R 18,43,44	90 364 - 101	" 100 K, 1/4W, 5%		3		

TABLE 5 - 2 . READ/WRITE CONTROL PCB COMPONENTS

REF. DESIGN.	PART- Nr.	DESCRIPTION	QTY. PER ASSY. NR.	
			88 356-XXX	001
R 20, 21	90 364 - 680	RESISTOR 68 Ω , 1/4W, 5%	2	
R 27, 66	90 364 - 122	" 1,2K, 1/4W, 5%	2	
R 28, 41, 48, 51, 65	90 364 - 222	" 2,2K, 1/4W, 5%	5	
R 33	89 282 - 628	" 390 Ω , 1/2W, 5%	1	
R 35	89 284 - 216	" 1,78K, 1/4W, 1%	1	
R 37, 49	90 364 - 271	" 270 Ω , 1/4W, 5%	2	
R 38	90 364 - 471	" 470 Ω , 1/4W, 5%	1	
R 42	90 364 - 822	" 8,2K, 1/4W, 5%	1	
R 45	80 925 - 002	" 0,9 , 2 W, 5%	1	
R 47	80 250 - 257	POTENTIOMETER 2K	1	
R 54	89 284 - 340	RESISTOR 34,8K , 1/4W, 1%	1	
R 55	89 284 - 341	" 35,7K , 1/4W, 1%	1	
R 56	90 364 - 221	" 220 K , 1/4W, 5%	1	
R 61	90 364 - 393	" 39 K , 1/4W, 5%	1	
R 67	90 366 - 158	" 150 Ω , 2 W, 5%	1	
R 68	90 364 - 472	" 4,7K , 1/4W, 5%	1	
R 69	95 413 - 325	POTENTIOMETER 25 K	1	
R 70	90 364 - 123	RESISTOR 12 K , 1/4W, 5%	1	
R 73, 74	89 284 - 172	" 619 Ω , 1/4W, 1%	2	
R 75	90 364 - 561	" 560 Ω , 1/4W, 5%	1	
R 76, 77	89 284 - 345	" 39,2K , 1/4W, 1%	2	
R 78, 79	89 284 - 313	" 18,2K , 1/4W, 1%	2	
T 1	80 939 - 001	TRANSISTOR NPN BC338 - 16	1	
T 2	80 935 - 001	" PNP BC327/40	1	
T 3,4,5,8,9	90 327 - 003	" PNP 2N3906	5	
T 6,7	505004 - 001	" FET 2N5460	2	
TJ 1	80 836 - 206	CONNECTOR 6P	1	
TJ 2	80 836 - 204	" 4P	1	
1 A	80 955 - 001	IC 3470	1	
1 B	12 282 - 002	IC LM 339	1	
2 B, 3 B, 2 F	92 136 - 001	IC SN 7474	3	
4 B	97 607 - 001	IC SN 7407	1	
1 C, 5 F	385014 - 001	IC SN 75453	2	
1 D, 2 C	13 602 - 001	IC SN 7438	2	
5 D	80 937 - 001	IC SAA 1027	1	
6 D	94 526 - 001	IC 9602	1	
2 E	19 296 - 001	IC SN 7402	1	
3 E, 3 D	92 127 - 001	IC SN 7404	2	
4 E	14 588 - 001	IC SN 74221	1	
1 F	80 938 - 001	IC ESM 227N	1	
3 F	18 773 - 001	IC SN 7432	1	
4D	97 272 - 001	IC- SOCKET 14P	1	
	355031 - Y02	TESTPOINT GND ( SCOPE)	1	
	80 976 - 001	PLUG SHORT CIRCUIT	11	

TABLE 5 - 2 . READ/WRITE CONTROL PCB COMPONENTS (cont.)

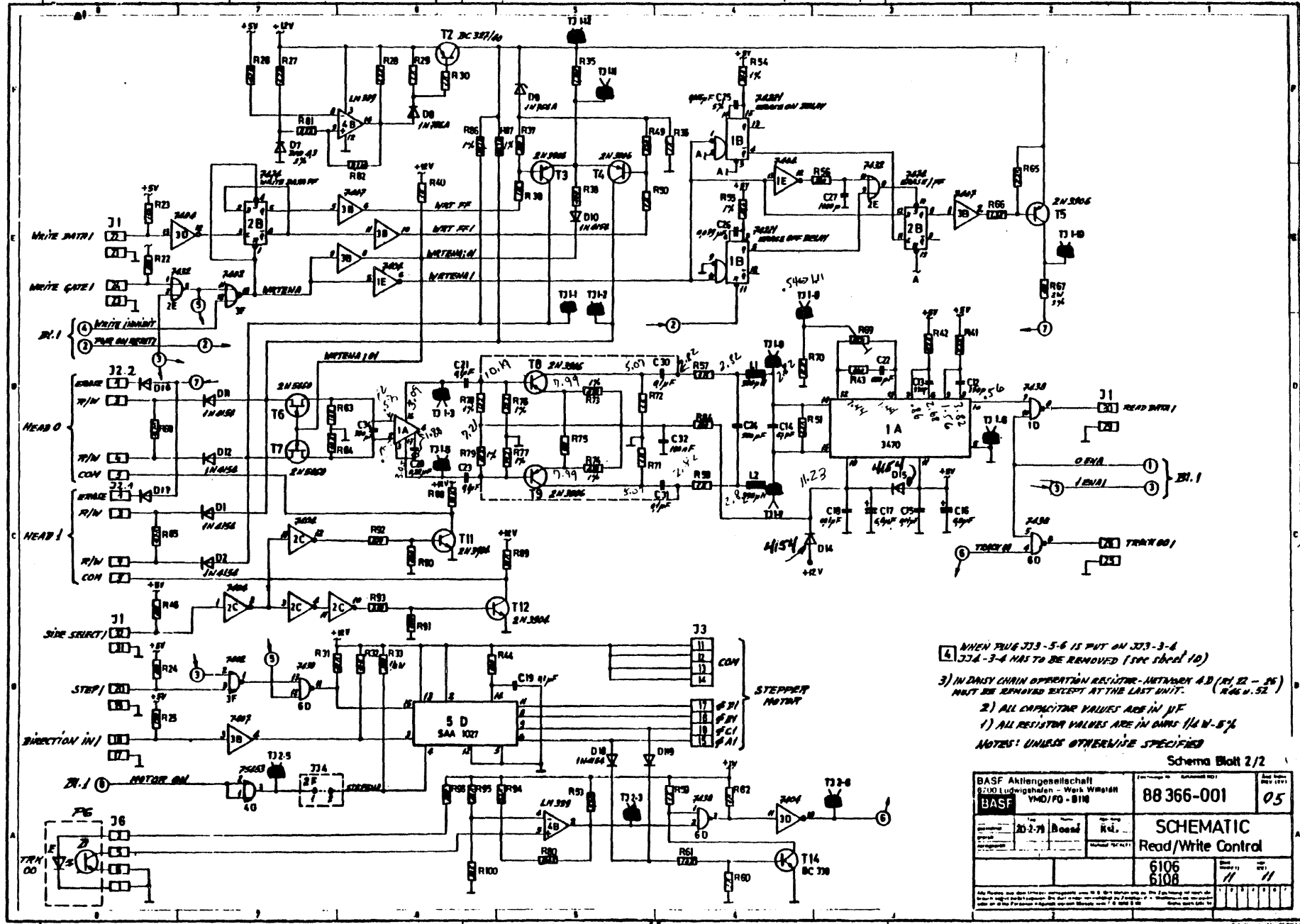

- 4) WHEN TRIG J13-5-6 IS PUT ON J13-3-4 J13-3-4 HAS TO BE REMOVED (SEE SHEET 10)
- 3) IN DASHY CHAIN OPERATION RESISTOR - ANTENNA 4.0 (R1, R2 - 2K) MUST BE REMOVED EXCEPT AT THE LAST UNIT.
- 2) ALL CAPACITOR VALUES ARE IN nF
- 1) ALL RESISTOR VALUES ARE IN OHMS (1/4 W-5%)
- NOTES: UNLESS OTHERWISE SPECIFIED

Schema Blatt 2/2

BASF Aktiengesellschaft 8200 Ludwigshafen - Werk W1001 VMD/PO - B10		88 366-001	05
20-7-71	Board	Kul.	SCHMATIC
		Read/Write Control	
		6106	///
		6108	///
<small>Alle Rechte sind dem Erfinder vorbehalten. Die Rechte sind durch Patente geschützt. Die Herstellung und der Verkauf aller Teile ist ohne schriftliche Genehmigung der BASF Aktiengesellschaft verboten. Die Rechte sind durch Patente geschützt. Die Herstellung und der Verkauf aller Teile ist ohne schriftliche Genehmigung der BASF Aktiengesellschaft verboten.</small>			

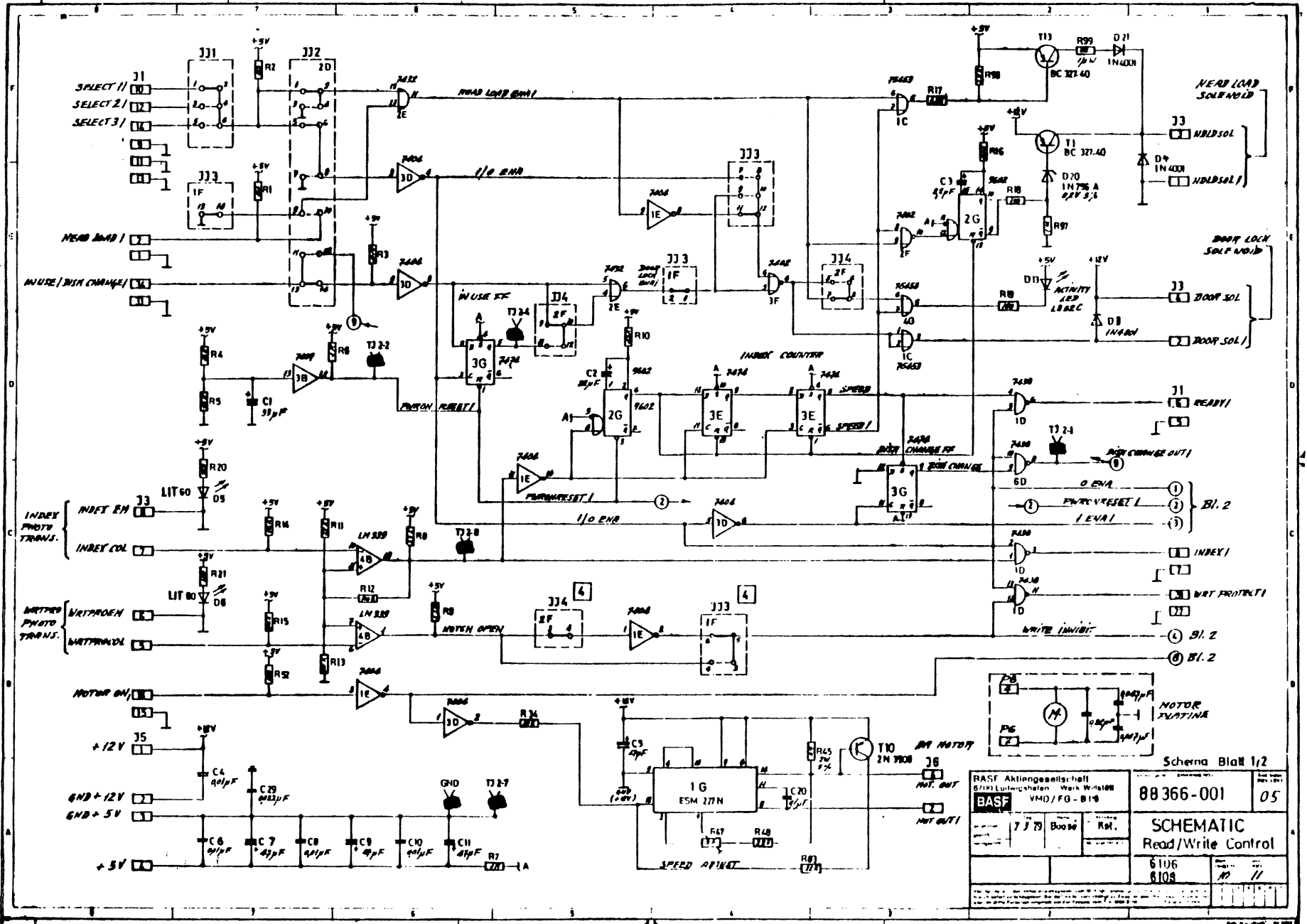

Schema Blatt 1/2

RASF Aktiengesellschaft GmbH Lützelshausen, Werk W-1108 BASF VMD/FG-B18		88 366-001	05
7/79 Boose Rel.		SCHEMATIC Read/Write Control	
		6106	11
		6108	